Operating manual
(Rel. 1.1)

Oxygen 7

Broadcast Console

PART II: OUTPUT MODULES



Via Caduti Di Sabbiuno 6/F • 40011 Anzola Emilia • Bologna • Italy ☎ +39 051 736555 • Fax. +39 051 736170
e-mail: info@axeltechnology.com • web site: www.axeltechnology.com

10 TABLE OF CONTENTS - PART II

10	TABLE OF CONTENTS - PART II	52
11	SUB MODULE.....	54
11.1	SUB MODULE - REMOTE CONNECTOR.....	54
11.1.1	EXTERNAL(audio) Input	54
11.1.2	LIST MIX – TB OUT	55
11.1.3	TB IN.....	55
11.1.4	remote TALKBACK enable (USER ACCESS).....	55
11.1.5	OPTO USER OUT	55
11.1.6	TB IN to CROOM.....	55
11.1.7	TB IN to STUDIO.....	55
11.1.8	INTERFACE PIN-OUT.....	56
11.2	APPLICATION: INTERCONNECTION BETWEEN 2 CONSOLES	57
11.2.1	AUDIO CONNECTIONS	57
11.2.2	LOGIC CONNECTIONS (ENABLING TALKBACK)	58
11.3	BLOCK DIAGRAM.....	59
11.4	INTRODUCTION	60
11.5	OUTPUT STAGE.....	61
11.6	MODULE OPTIONS AND JUMPER SETTINGS	62
11.6.1	Setting Sub Module as SUB 1 or SUB 2.....	64
11.7	EXT SWITCH AND FADER CONTROL	67
11.8	COMPRESSOR	68
11.9	AUX SEND	69
11.10	BALANCE.....	69
11.11	MASTER-SUB1-SUB2 ROUTING SWITCHES	70
11.12	DUCK SWITCH.....	70
11.13	PFL BUTTON.....	71
11.14	TALK BUTTON	72
11.15	ON LED	72
11.16	FADER	73
11.17	DETECT LED	73
12	MASTER MODULE.....	74
12.1	MASTER MODULE - REMOTE CONNECTOR	74
12.2	INTERFACE PIN-OUT.....	74
12.2.1	MASTER INSERT point.....	75
12.2.2	REMOTE SELECTION CONTROL.....	76
12.3	BLOCK DIAGRAM.....	77
12.4	INTRODUCTION	78
12.5	MASTER OUTPUT.....	79
12.6	TUNER INPUT.....	79
12.7	MODULE OPTIONS AND JUMPER SETTINGS	80
12.8	STUDIO SPEAKER SECTION.....	82
12.9	DUCK MIX SECTION	84
12.10	AUX CONTROL.....	84
12.11	CONTROL ROOM HEADPH. SECTION.....	85
12.12	DIRECT DUCK.....	86
12.13	PFL RESET BUTTON.....	86
12.14	TALK BACK BUTTON.....	86
13	MONITOR MODULE.....	88
13.1	MONITOR MODULE - REMOTE CONNECTOR.....	88
13.2	INTERFACE PIN-OUT.....	88

13.3	BLOCK DIAGRAM.....	89
13.4	INTRODUCTION	90
13.5	PWS INPUT.....	91
13.6	MONO OUTPUT.....	91
13.7	STUDIO – C.ROOM HEADPH SOCKETS	91
13.8	VU METER CONNECTION.....	91
13.9	CONTROL ROOM SPEAKER SECTION	92
13.10	PFL ADJ POTENTIOMETER	94
13.11	MONO MONITOR SWITCH.....	94
13.12	AUX OUTPUT CONTROL	94
13.13	CONTROL ROOM HEADPH. SECTION.....	94
13.14	MONITOR TO METER SWITCH	95
13.15	C.ROOM HEADPHONE SOCKETS.....	96
14	POWER SUPPLY.....	97
14.1	DESCRIPTION	97
14.2	PWS RELAYS.....	98
14.3	MIXER CONNECTIONS.....	98
14.4	MAIN AC VOLTAGE SETTINGS	99
14.5	PWS TROUBLESHOOTING.....	99
15	METERBRIDGE.....	101
15.1	INTRODUCTION	101
15.2	VU METER ASSIGNEMENTS	102
15.3	VU METER SETTING.....	102
16	WARRANTY.....	104
17	DIMENSIONS.....	104

11 SUB MODULE

11.1 SUB MODULE - REMOTE CONNECTOR

The 15 pin D-Type plug remote connector provides the inputs and outputs for the following functions :

- Remote Start / Stop for equipment connected to Input A
- Remote Start / Stop for equipment connected to Input B
- External Talkback activation
- Remote control for the channel On/Off
- External Duck Control

A 6 Vdc \pm 50 mV current-limited output is also provided for use with the remote control inputs.

In some applications multiple Oxygen 7 units may be used together to create a multi-channel system. To assist in this purpose, Sub interface has been especially designed, allowing two Oxygen 7's models to be easily interconnected.

In particular:

AUDIO CONNECTIONS

- SUB output from the first console is intended to be connected to EXT input of the second console and viceversa to exchange mixed audio material
- LIST MIX & TB OUT output from the first console is intended to be connected to TB IN input of the second console and viceversa for TalkBack communication exchange.

LOGIC CONNECTIONS

- Remote TALKBACK enable (USER ACCESS) on the Sub module
- Remote control of the Talkback to CROOM audio path
- Remote control of the Talkback to STUDIO audio path
- External TALK enable (Opto user)

11.1.1 EXTERNAL(audio) Input

Stereo input, line level, electronically balanced. It is mainly intended to be connected to off-air, microwave, or satellite receivers. It may be also used for connection to an external Sub module, for audio exchange between two Oxygen 7 consoles. **External Input is labeled EXT 1 on the Sub 1 module and EXT 2 on the SUB 2 module.** Sub modules present the same electronic layout and they are configured as Sub 1 or Sub 2 via jumpers (ref to Section 11.6)

External Inputs can be monitored via the Studio and CRoom Speaker sections.

11.1.2 LIST MIX – TB OUT

Mono output, electronically balanced. It provides Master, Sub 1 or Sub 2 (in mono mode) depending on the module setting (ref to Section 11.6). **It outputs also TB (to STUDIO) signal** whenever TalkBack to External jumper is closed (ref to Section 11.6).

11.1.3 TB IN

Electronically balanced, mono input. It is intended to be used in connection with LIST MIX&TB OUT output or for audio communication exchange between audio consoles. TB IN audio signal may be routed to TB to CROOM path when pin 13 ('TB IN to CROOM') is connected to GND and to TB to STUDIO path when pin 12 ('TB IN to CROOM') is connected to GND.

Please, remind to set jumpers on the Master module accordingly (External TB routing jumpers – ref to Section 12.7).

11.1.4 remote TALKBACK enable (USER ACCESS)

A pushbutton needs to be connected to the pins 10 and 11 (GND) of the interface (it is an active-low control). Using the pushbutton, the announcer can remotely switch On/Off the Talkback audio path. This control has the same function as the 'Talk' button on the Sub module. Ref to Section 11.6 for Momentary/Latched button operation.

11.1.5 OPTO USER OUT

When the Talk function on the Sub module is active, the 'Opto User Out' optocoupler applied between pins 6 and 5 will close. It can be used to remotely activate Talk path in the inter-connected Oxygen 7 console.

Please, consider that max current allowed on optocouplers is 10 mA (nominal: 5 mA). Apply the provided + 6V tension through a **560 Ω carbon resistor** in order to preserve optocouplers from extra currents.

11.1.6 TB IN to CROOM

It is an active-low logic control (to activate, pin 13 must be connected to GND = Pin 11). When activated, it allows an external talkback audio signal (from TB IN audio connector) to appear on the CROOM Speakers and/or CROOM headphones (ref to External TB routing jumpers on Master module –Section 12.7).

11.1.7 TB IN to STUDIO

It is an active-low logic control (to activate, pin 12 must be connected to GND = Pin 11). When activated, it allows an external talkback audio signal (from TB IN audio connector) to appear on the STUDIO Speakers and/or STUDIO headphones (ref to External TB routing jumpers on Master module –Section 12.7).

11.1.8 INTERFACE PIN-OUT

SUB D 15P FEMALE

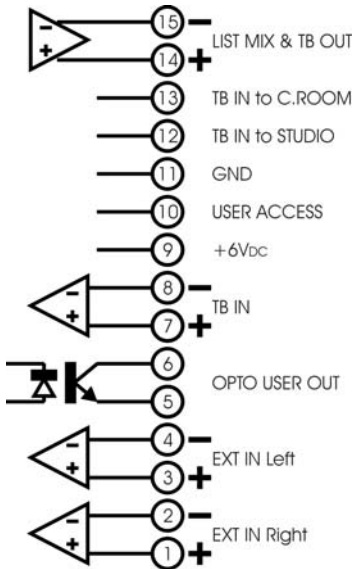

PIN	DESCRIPTION	DIRECTION
15	Cold- Out of phase Listening / TalkBack Output	OUT
14	Hot – In phase Listening / TalkBack Output	OUT
13	Talkback-into-CRoom enable	IN
12	Talkback-into-Studio enable	IN
11	Ground - GND	
10	External command enabling	IN
9	+ 6 V DC	OUT
8	Cold - Out of phase External TalkBack Input	IN
7	Hot – In phase External TalkBack Input	IN
6	Collector of photocoupler - User command	OUT
5	Emitter of photocoupler - User command	OUT
4	Cold- Out of phase External Input Left Channel	IN
3	Hot – In phase External Input Left Channel	IN
2	Cold- Out of phase External Input Right Channel	IN
1	Hot – In phase External Input Right Channel	IN

11.2 APPLICATION: INTERCONNECTION BETWEEN 2 CONSOLES

11.2.1 AUDIO CONNECTIONS

SUB / EXT audio exchange.

When Sub output (console # 1) and Ext input (console # 2) and viceversa are connected, audio signal flows from the one console to the other, allowing a mixing (Sub) signal from the first console to be broadcast via the Master output of the console # 2 and viceversa

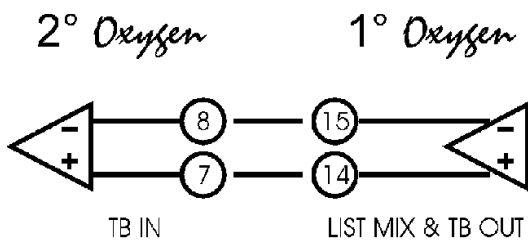

TALKBACK audio exchange

TB signal from the consoles may exchanged via the **LIST MIX / TB OUT** outputs and **TB IN** inputs in order to allow off-air communication between two consoles.

LIST MIX output provides Master, Sub 1 or Sub 2 signals, that are replaced by TB (to STUDIO) signal when Talk button is pressed or Talk is activated by an external control.

Example

if You want to use the Croom microphone to speak to the announcer's headphones situated in a remote studio (and therefore assisted by Oxygen 7 console # 2) please follow these steps:

On the console # 1:

- 1) close TB STUDIO jumper on the Mono (microphone) module
- 2) Close the TALK TO EXT jumper on the Sub module you are connecting to (ref to Sect 11.6)
- 3) Press 'TALK' button on the Sub module. Talk activation may be set as 'momentary or impulsive' depending on the MOM ACCESS jumper on the Sub module (ref to Sect 11.6)

On the console # 2

- 4) enter TB audio signal into the TB IN input
- 5) Close to GND 'TB IN to STUDIO' pin (# 12) on Sub module remote interface – see next paragraph
- 6) Close the HEAD / STUDIO / EXT jumper on the Master module (ref to Section 12.7)

NB this connection can be reversed to allow engineer at Console # 2 to speak f.i. to Studio headphones of console # 1

11.2.2 LOGIC CONNECTIONS (ENABLING TALKBACK)

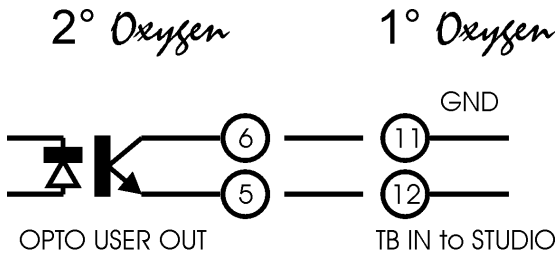

OPTO USER OUT / TB IN to STUDIO or CROOM

To allow audio engineer at the console # 1 to remotely enable TB communications into console # 2 speakers / headphones, Opto User Out pins should be connected to *TB IN to STUDIO* or *TB IN to CROOM* pins of the Sub interface – console # 2.

Example:

if You want to use the Croom microphone to speak to the announcer's headphones situated in a remote studio (and therefore assisted by console # 2), the remote control connection must be performed as following :

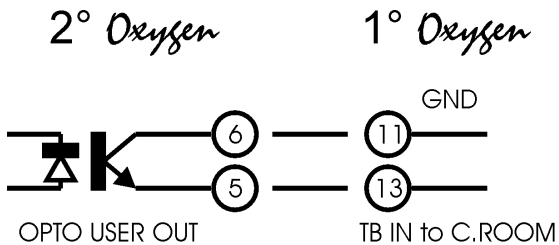

On the console # 1:

- 1) close TB STUDIO jumper on the Mono (microphone) module
- 2) Close the TALK TO EXT jumper on the Sub module you are connecting to (ref to Sect 11.6)
- 3) Connect Pin 5 and 6 of the interface console # 1 (Opto User Out) to Pins 11 and 12 of the remote interface - console # 2.
(pressing 'TALK' button on the Sub module will activate TalkBack to Studio on the console # 2. TalkBack button may be set as 'momentary or impulsive' depending on the MOM ACCESS jumper on the Sub module (ref to Sect 11.6)

On the console # 2

- 1) Close the HEAD / STUDIO / EXT jumper on the Master module (ref to Section 12.7)

NB this connection can be reversed to allow engineer at Console # 2 to speak f.i. to Studio headphones of console # 1.

11.3 Block Diagram

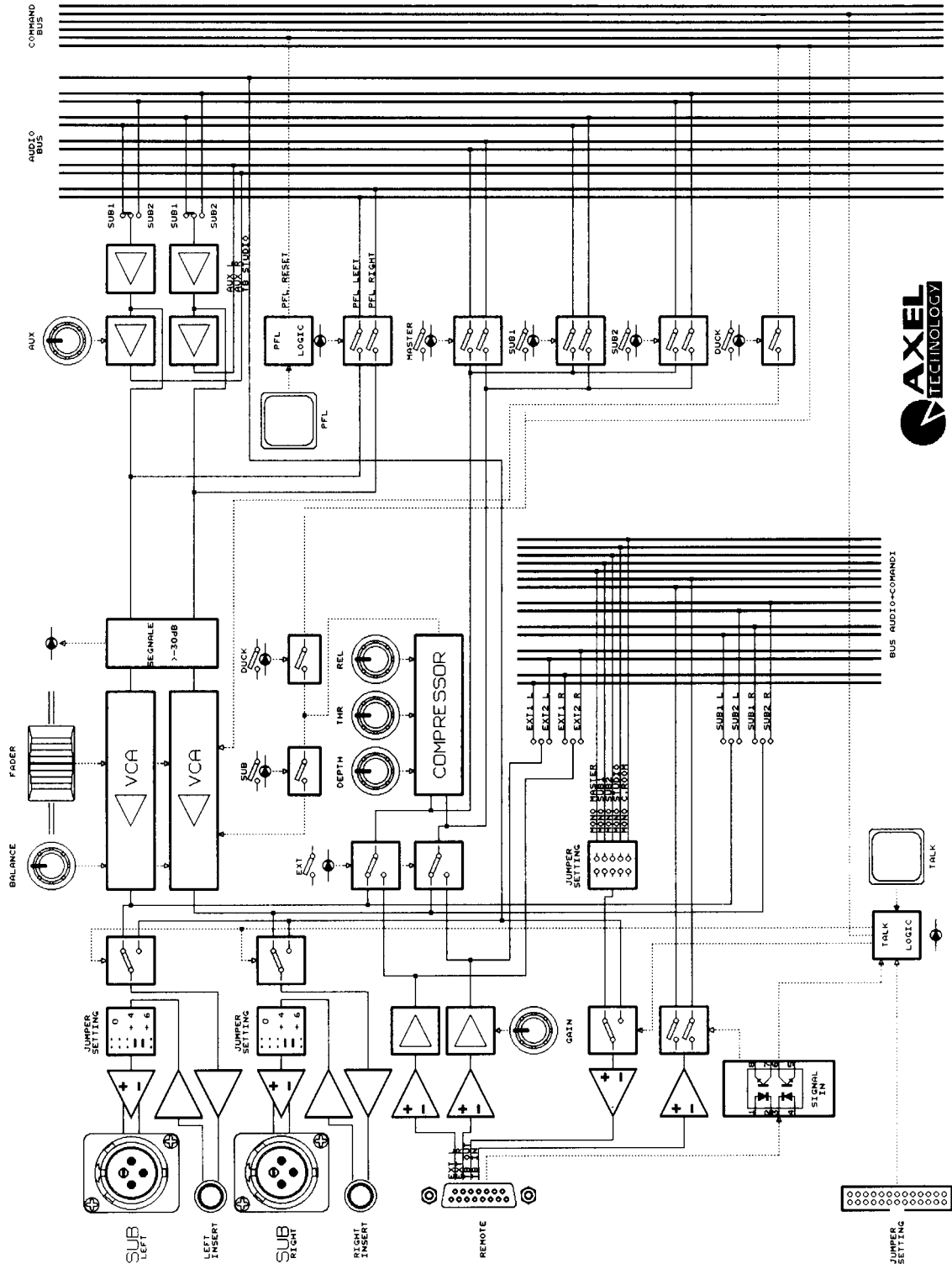

11.4 INTRODUCTION



Each of these two optional modules contains a summing amplifier, fader and output amplifier for each of the two stereo subgroup busses. As well as having its own independent output, each stereo subgroup signal can be routed to the Master output, allowing them to be used as audio subgroups primarily for production applications.

The subgroup outputs can be of course be used as recording outputs or clean feeds for other parts of a broadcasting facility. Both the prefade signal and the Sub outputs are available for monitoring.

As part of the module there is a Stereo return input which may be routed via an input potentiometer to either of the stereo subgroup busses or the Master output.

Oxygen 7's SUB module provides also facility for interconnections between two Oxygen 7's models.

Sub module has provision for a bidirectional talkback system with both DC and audio being generated from the console and fed to external destinations (such as another Oxygen 7 console) and controlling signals plus audio signal being fed into the console for return talkback. This allows two Oxygen 7's models to be easily interconnected.

The operator's or the announcer's / DJ's mic may be used as the source for the talkback send to an external destination.

External talkback signals can be switched by the external control line into the Oxygen 7's Studio/Croom headphones and loudspeaker monitors.

11.5 OUTPUT STAGE

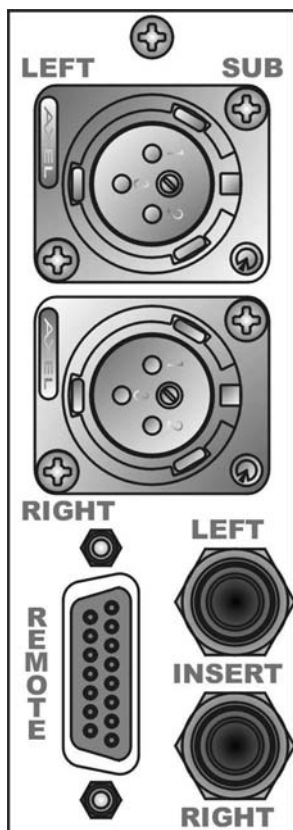

The SUB male XLR connector provide an electronically balanced output from the SUB bus.

All the consoles are set for a 0 dBm Master output level at the time of factory test.

Sub output is however compatible with nominal level of **+4 dBm** and **+ 6 dBm**.

Four jumpers, located on the front panel of the module, are used to set the output sensitivity. Refer to the *module jumper setting 12.7* section of this guide for configuration details.

Two unbalanced **INSERT** sockets (Left and Right channels) are provided which are a break point in the output channel signal path. The insert point allows external piece of equipment such as limiters, compressors and other signal processing units to be added as required.

The Insert are a 3-pole 1/4" 'A' gauge Jack Socket, which are normally by-passed. When a jack plug is inserted, the signal path is broken at a point just before the final output stage. The signal from the channel appears on the TIP of the plug and is returned on the RING to continue through to the final output.

Input impedance is 10 K Ω , output impedance is 100 K Ω .

Ref to Section 11.2 in case of interconnection between two oxygen 7 audio consoles.

11.6 MODULE OPTIONS AND JUMPER SETTINGS

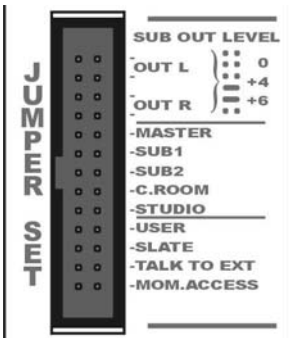

The first four jumpers select the **Sub output level** (ref to Section 11.5). Close Jumpers accordingly to the configurations here below displayed



LIST MIX & TB OUT ROUTING jumpers

Talkback lets the operator talk to one or more console outputs, for example to communicate with announcer in the Studio booth through the Studio monitor speakers or the Studio headphones. This section houses all controls needed to communicate with every connected source to the Oxygen 7.

When closed, the MASTER jumper let the Master signal appears on the LIST MIX & TB OUT output (see Sub Remote Interface – Section 11.1).

When closed, the SUB 1 jumper let the Sub 1 (pre-fader) signal appears on the LIST MIX & TB OUT output (see Sub Remote Interface – Section 11.1).

When closed, the SUB 2 jumper let the Sub 2 (pre-fader) signal appears on the LIST MIX & TB OUT output (see Sub Remote Interface – Section 11.1).

CROOM and STUDIO Jumpers are DISCONNECTED

USER jumper

When the **USER** jumper is closed, **relay** switch #1 inside the Power Supply (or #2, depending on the module settings – ref to Section 11.6, Jumper J2 and J3) closes when the TalkBack function is enabled, either by pressing the Talk button on the Sub module, or by activating remote Talk command (User access) on the Sub Remote Interface – ref to Section 11.1.4.

SLATE jumper

When the SLATE jumper is closed, SLATE function will send the TB to STUDIO mic signal to the Sub stereo output with TALK button pressed, allowing the engineer to record memos and voice communications via the Sub output. TB signal will replace existing Sub signal as long as the Talk button is pressed.

TALK TO EXT jumper

When the TALK TO EXT jumper is closed, LIST MIX & TB OUT will present TalkBack signal (coming from MONO module set as TB to STUDIO/EXT) replacing existing output (Master, Sub 1 or Sub 2) whenever Talk button is pressed (ref to 11.14)

MOM.ACCESS jumper

The **MOM.ACCESS** jumper allows two TALK operating modes. The TALK function may be operated in latched or momentary mode, depending on MOM ACCESS jumper:

When the Jumper is closed, TALK is operated in momentary mode
When the Jumper is opened, TALK is operated in latched mode

Oxygen 7 - SUB MODULE

11.6.1 Setting Sub Module as SUB 1 or SUB 2

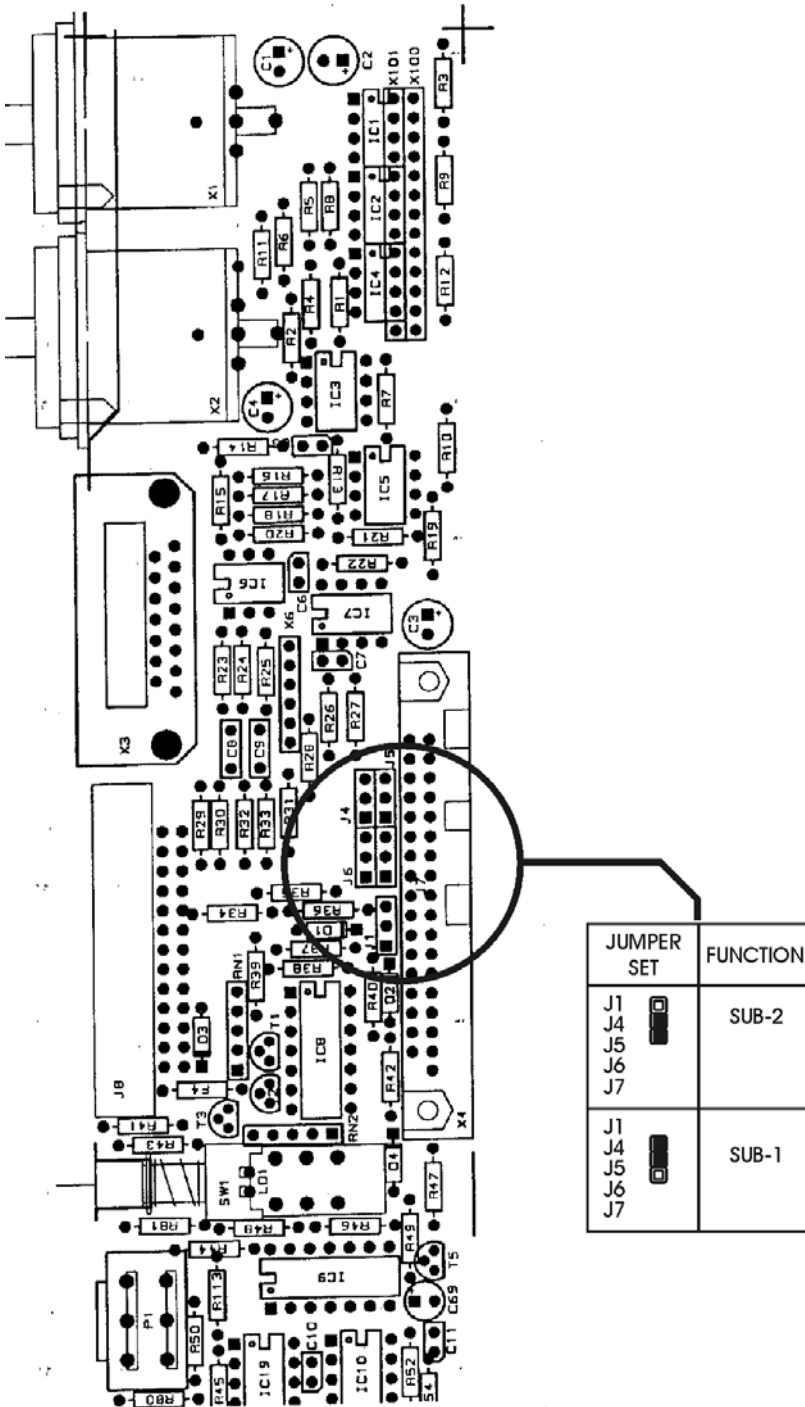

Oxygen 7 - SUB MODULE

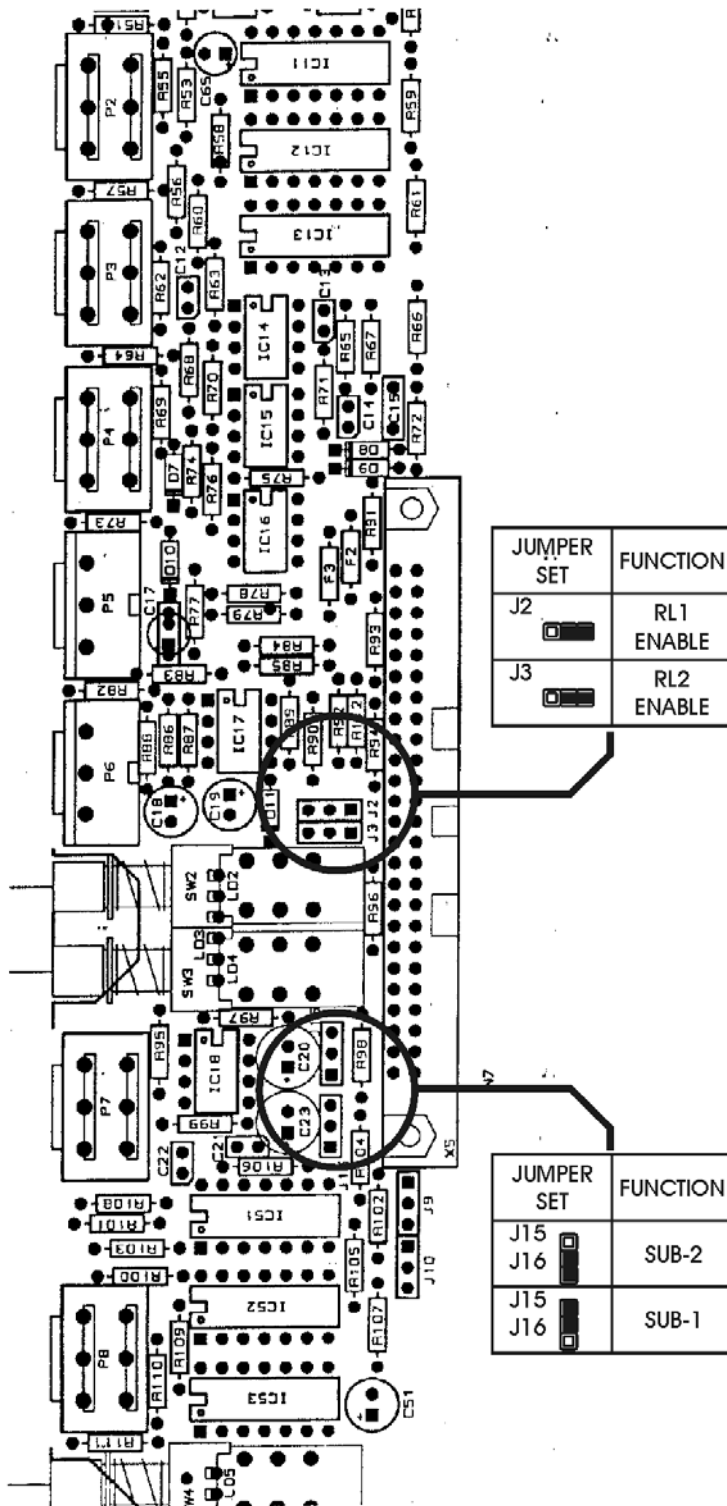

Oxygen 7 - SUB MODULE

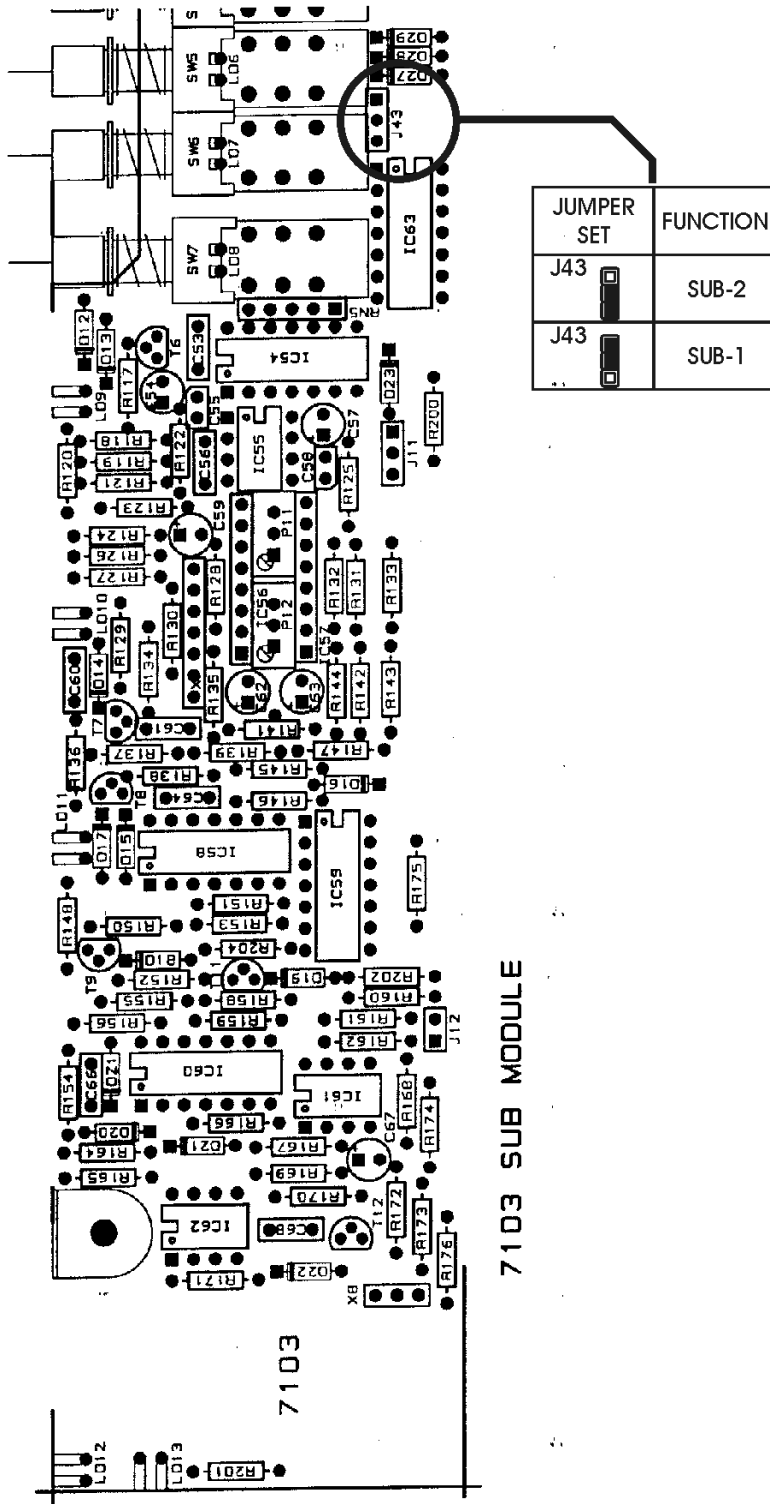

11.7 EXT switch and FADER control

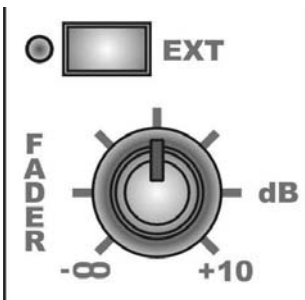

The EXTERNAL FADER control gives continuous adjustment of the EXTERNAL signal that feeds from the EXT input (ref to Section 11.1.1) from +10 dB to Off.

External Input is labeled EXT 1 on the Sub 1 module and EXT 2 on the SUB 2 module.

EXT input is mainly intended to be connected to off-air, microwave, or satellite receivers. It may be also used for connection to an external Sub module, for audio exchange between two Oxygen 7 consoles. It can be also monitored via the Studio and CRoom Speaker sections.

When the EXT switch is pressed, the existing inputs to the Sub module are disabled and are replaced by the EXT input signal. EXT signal flows from the EXT inputs, is faded by (EXT) FADER potentiometer, feeds Compressor stage and is finally routed to SUB 1, SUB 2 or MASTER output, regardless of SUB module assignement (Sub 1 or Sub 2), etc.

Please note that Sub XLR module outputs (Left and Right) may reproduce EXT signal (with slider control) when Sub 1 (Sub2) routing switcher is pressed for Sub 1 (Sub 2) module. NOTE: with EXT button pressed, the SUB XLR outputs will reproduce Ext signal mixed to any further source routed as Sub 1 (Sub 2).

With EXT button depressed

- Sub Fader → Dims SUB signal
- PFL button → Enable 'sub' signal prefader listening
- AUX potentiom. → controls the 'Sub' signal on AUX bus
- DETECT LED → Shows 'Sub' signal presence
- SUB XLR connectors → Provide 'Sub' signal
- DUCK button → Acts on the 'Sub' signal
- MST/SUB1/SUB2 switch → Route 'Sub' signal

With EXT button pressed (regardless of other buttons)

- AUX potentiom. → controls the EXT signal on AUX bus

With EXT button pressed & Sub 1 or Sub 2 pressed (accordingly to SUB module assignement – Sub 1 or Sub 2)

- Sub Fader → Dims EXT signal
- PFL button → Enable EXT signal prefader listening
- BAL knob → Controls EXT signal
- DETECT LED → Shows EXT signal presence
- SUB XLR connectors → Provide EXT signal
- DUCK button → Acts on the EXT signal
- MST/SUB1/SUB2 switchers → Route EXT signal

11.8 COMPRESSOR

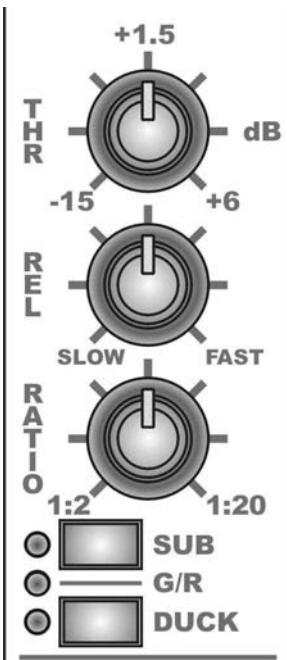

A studio-quality compressor circuit may be associated with the Sub or EXT signal. It may act on the Sub output signal or on the Duck circuitry.

THRESHOLD

Threshold is the level of the incoming signal at which the compressor amplifier changes from a unity gain amplifier into a compressor reducing gain. The compressor has no effect on the signal below the threshold level setting. Once threshold is reached, the compressor starts reducing gain according to the amount the signal exceeds threshold and according to the ratio control setting.

REL (Release)

Release time is the time the compressor uses to return to unity gain after the input signal has fallen below threshold. The RELEASE control allows you to select a release action from slow to fast.

RATIO

Ratio expresses the degree to which the compressor is reducing dynamic range. Ratio indicates the difference between the signal increase coming into the compressor and the increase at the output level. A ratio of 1:10 would mean that it would take an increase of 10 dB coming into the compressor to cause the output to only increase 1 dB.

G/R (Gain Reduction) LED

The GAIN REDUCTION LED shows the extent to which the compressor is reducing the gain (the LED glows at maximum intensity whenever the maximum gain reduction is performed).

Two buttons select the compressor status:

- when the button is in the out position (i.e. depressed) the compressor is not active
- when the Sub button is pressed, high signal levels on the Sub audio bus will be automatically attenuated via VCA circuit (i.e. the Compressor stage is applied to the Sub output). In case of EXT button pressed (ref to Section 11.7), Compressor will be driven by (and applied to) the External signal.
- when the Duck button is pressed, high signal levels on the Duck audio bus will be automatically attenuated via VCA circuit

EXAMPLE # 1

If You want to automatically fade background music in relationship with the announcer 's speech (**VoiceOver** facility):

1. Press *Master* and *Duck* buttons on the module (f.i. a Stereo one) dealing with background music
2. Make sure, Master output provides background audio material
3. Press *Sub 1* (*Sub 2*) button on the Mono (microphone) module (to allow microphone's signal drive the Compressor)
4. Route to *Master* the Sub 1 (*Sub 2*) output signal (ref to Section 0) (to

- allow microphone's signal go 'on air')
5. Make sure, Master output provides microphone signal
 6. Press *Duck* on the Compressor stage
 7. Press *Direct Duck* on the Master module
 8. Adjust Compressor's controls

EXAMPLE # 2

If You want to automatically limit (compress) Sub output accordingly to Sub (source) signal

1. Route input audio material to Sub 1 (Sub 2) module
2. Make sure, Sub 1 (Sub 2) output provides audio material and EXT button is released
3. Press *Sub* button on the Compressor stage
4. Adjust Compressor's controls

11.9 AUX SEND



This control sends the input channel signal to the Auxiliary bus (range $-\infty$ to 0 dB max). As AUX bus is separated from the main outputs, it can provide additional output for foldback, echo units or extra loudspeaker feed.

AUX signal is always derived after the EQ section (and pre-fader). Ref to Section 11.7 for AUX assignment in conjunction with EXT button.

11.10 BALANCE



It adjusts the balance between the L and R outputs. At the detented centre position the signal routes equally to L and R.

Ref to Section 11.7 for BALANCE assignment in conjunction with EXT button.

11.11 MASTER-SUB1-SUB2 ROUTING SWITCHES

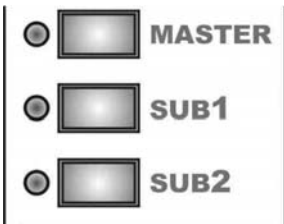

The input channel signal may be routed to the main Stereo MIX (L-R) or pairs SUB busses 1 & 2 by pressing the respective switches.

The routing switchers work in conjunction with the module status (On or Off)

There is a red LED next to each switch which will illuminate at two levels of brightness.

The LED will illuminate at half brightness if the Switch is pressed but the module is Off.

You may regard this as the routing circuit being armed but not active.

To make it active the On status must be engaged (see §). The LED will illuminate at full brightness to indicate that the circuit is now active.

When one or more routing switchers are depressed, LED is off and the routing circuit is never active, regardless of the module status (On/Off).

LED OFF switch depressed / the status of the module doesn't affect routing circuit

LED ON switch pressed / routing circuit is active as the module is On

LED HALF BRIGH. switch pressed / routing circuit is non active as the module is Off

This three mode operating has been introduced in order to prevent buss from additional noise when routing switchers are pressed and module is off.

The Sub mix can be mixed into the main output mixbus in the master section (see Master routing switcher on the Sub modules).

This is a convenient way to use the SUB assignment switch as a subgroup system, creating new possibilities in the Oxygen 7 console.

Ref to Section 11.7 for signal Routing in conjunction with EXT button.

11.12 DUCK SWITCH



The Duck is an ON/OFF switch which tells each VCA fader whether or not they participate in the external Duck control.

Please ref to Chapter 6.

The DUCK switcher works in conjunction with the module status (On or Off)

There is a red LED next to the switch which will illuminate at two levels of brightness.

The LED will illuminate at half brightness if the switch is pressed but the module is Off.

You may regard this as the DUCK routing circuit being armed but not

active.

To make it active the On status must be engaged (see §). The LED will illuminate at full brightness to indicate that the circuit is now active.

When the switch is depressed, LED is off and the circuit is never active, regardless of the module status (On/Off).

LED OFF	switch depressed / the status of the module doesn't affect routing circuit
LED ON	switch pressed / DUCK circuit is active as the module is On
LED HALF BRIGH.	switch pressed / DUCK circuit is non active as the module is Off

This three mode operating has been introduced in order to prevent buss from additional noise when switch is pressed and module is off.

Ref to Section 11.7 for Duck operation in conjunction with EXT button.

11.13 PFL button

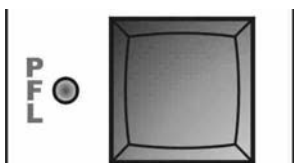

Stereo pre-fade listening. PFL button (operated only in latched) mode allows pre-fade listening (post pan-pot) of the channel with the fader closed.

When the PFL button is activated, the channel signal will be connected to the PFL output and to the CUE single-meter circuitry. Even when the channel is active, the PFL system is active.

The PFL function can be cancelled:

- by using the PFL RESET button on the MASTER Module
- by activating PFL on another module (if PFL MODE Jumper on the Master module is open – see Master module Jumper settings)
- by pressing the PFL button again

The PFL signal can be heard by way of external headphones and amplifiers with loudspeaker connected to the Control Room and / or Studio sections – please refer to § Master and Monitor module descriptions.

The user may chose among two PFL operating modes: ADDITIVE or SINGLE

- In the ADDITIVE Mode, You can listen to one or more PFLs at the same time by pressing one or more PFL keys
- In the SINGLE Mode, only one PFL is active at once

Please refer to PFL MODE jumper on the MASTER Module (§ 12.7).

PFL RESET key will always disable all the active PFL keys, regardless of PFL MODE jumper.

Ref to Section 11.7 for PFL operation in conjunction with EXT button

11.14 TALK button

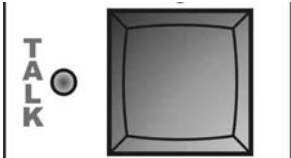

The TALK button allows people to transmit talkback to the Sub Output ('Slate' function) and/or to an external destination, accordingly to SLATE and TALK TO EXT **Jumper** setting (ref to Section 11.6).

- **SLATE** function allows to send a voice cue or a voice identification message to a recording medium via the Sub output.
- From the factory the Talk button is set to latch. The Talk button may be operated also in **momentary** mode, depending upon how you have set the MOM ACC jumper (ref to Section 11.6).
- **TALK TO EXT** jumper allows You to route the TB audio to the LIST MIX/TB OUT output (ref to Sub remote interface - 11.1)

Talk function may be also remoted via the User Access pins on the Sub Remote Interface. TALK LED will glow when Talk is activated either by the button, or by the external command. (ref to Sub Remote Interface – Section 11.1).

11.15 ON LED

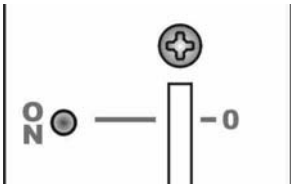

It will glow when the channel is in the ON status.

11.16 FADER

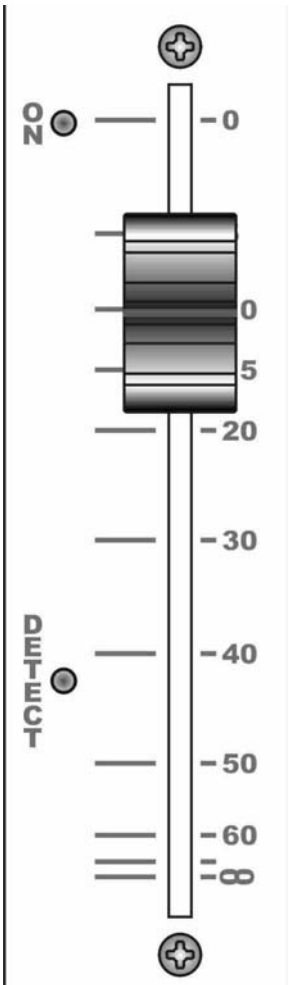

The fader is an ultra smooth 100 mm ALPS K-Series model controlling the internal high quality VCA circuitry.

There is no audio going through the faders which guarantees noise free fading for ever! (see Chapter 6 on VCA circuit).

When the fader is closed, the signal is automatically muted, providing a cut-off in excess of 100 dB. This high dB cut-off value ensures that the main output is protected from crosstalk from announcers or fast spooling tape decks.

The scale shows the attenuation. Normal operating position is at the '0' mark, providing overall 0 dB of gain.

Moving the fader away from its down position brings the module in its ON status.

Ref to Section 11.7 for FADER control in conjunction with EXT button

11.17 Detect LED

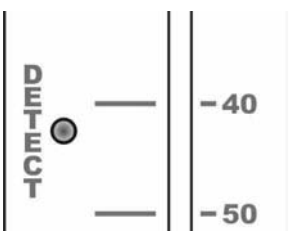

The Detect LED illuminates when a signal > -30 dB is present on the selected input (Sub or EXT). The control is performed PRE-FADER.

Ref to Section 11.7 for LED operation in conjunction with EXT button

12 MASTER MODULE

12.1 MASTER MODULE - REMOTE CONNECTOR

The 15 pin D-Type plug remote connector provides the inputs and outputs for the following functions :

- Stereo line-level (max + 10 dB) output for connection to a power amplifier associated with a pair of **studio** monitor loudspeakers. The output is electronically balanced, and can drive balanced or unbalanced loads of 600 ohms or greater. To connect to an unbalanced load tie the Cold pole to GND.
- **Insert** connection for the **Master** output
- Remote control of the input source (Tuner, Master, Aux) to be listened in the studio booth.

A 6 Vdc ± 50 mV current-limited output is also provided.

12.2 INTERFACE PIN-OUT

SUB D 15P FEMALE

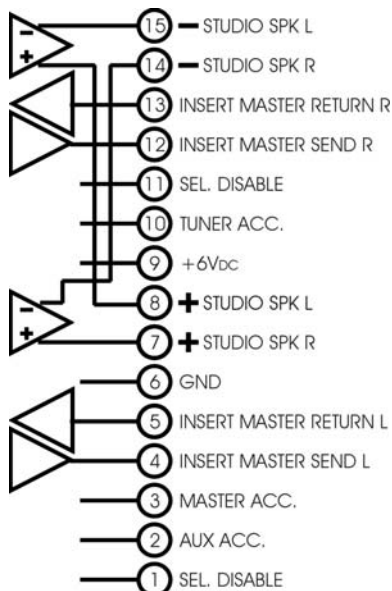

PIN	DESCRIPTION	DIRECTION
15	Studio speaker output Cold (Out-of-Phase) Left channel	OUT
14	Studio speaker output Cold (Out-of-Phase) Right channel	OUT
13	Master insertion point / Return of Right channel	IN
12	Master insertion point / Send of Right channel	OUT
11	Remote PFL (Cue) disable	IN
10	Remote Tuner source selection	IN
9	+ 6 V DC	OUT
8	Studio speaker output Hot (in-Phase) Left channel	OUT
7	Studio speaker output Hot (in-Phase) Right channel	OUT
6	Ground GND	/
5	Master insertion point / Return of Left channel	IN
4	Master insertion point / Send of Left channel	OUT
3	Remote Master source selection	IN
2	Remote AUX source selection	IN
1	Remote reset of the present Studio speaker selection	IN

12.2.1 MASTER INSERT point

The Pin 12 sends the Right channel Master signal to an external equipment (compressor, processor, etc) and on the Pin 13 the signal returns to the module.

The Pin 4 sends the Left channel Master signal to an external equipment (compressor, processor, etc) and on the Pin 5 the signal returns to the module.

As the Master signal for monitoring is taken across the XLR output connectors, Insert Master circuitry allows You to listen to the final result of Master signal + external (inserted) effect.

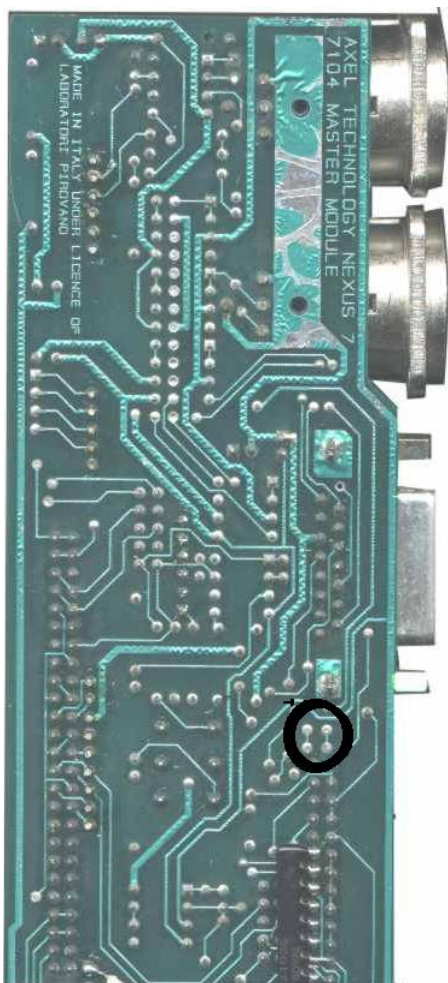

NOTE:

Master Insert point is **factory preset as bypassed** (i.e. Pins 12 and 13 / 4 and 5 are shortcircuited via PCB links and no external electric bridge is required).

To enable the Insert circuit, please **remove (cut) these links** using an appropriate blade (PCB soldering side). The links are situated on the module PCB, behind the 'Jumper Set' connector (see picture here closed).

12.2.2 REMOTE SELECTION CONTROL

A multi-pole cable can be connected between the Interface remote connector and an external (remote) keyboard with 5 pushbuttons or contact closure (SEL DISABLE; CUE DISABLE; MASTER ACCESS; TUNER ACCESS; AUX ACCESS).

Using the push-buttons during broadcast or other special application, the announcer situated in the studio booth can remotely control (select) the source to be monitored via the Studio speakers.

In particular, the announcer can remotely reset any active PFL and current selection (ref to Section) and replace the current monitored source with the Master / Tuner and Aux one.

SEL(ECTION) DISABLE

When this Pin is connected to GROUND (GND), Studio speaker output will be muted from all assigned buses (Studio Speaker Selection) for as long as the SEL(ECTION) DISABLE Pin is grounded.

MASTER (BUS) ACCESS

When this Pin is connected to + 6V, Studio speaker output will automatically reproduce Master bus, (i.e. the normal Studio monitor source will be interrupted and the Master signal monitored in its place) for as long as the Pin is powered.

TUNER (BUS) ACCESS

When this Pin is connected to + 6V, Studio speaker output will automatically reproduce Tuner bus, (i.e. the normal Studio monitor source will be interrupted and the Tuner signal monitored in its place) for as long as the Pin is powered.

AUX (BUS) ACCESS

When this Pin is connected to + 6V, Studio speaker output will automatically reproduce Aux bus (i.e. the normal Studio monitor source will be interrupted and the Aux signal monitored in its place) for as long as the Pin is powered.

CUE DISABLE

When this Pin is connected to + 6V, the Cue Disable circuitry will be active meaning that any activated PFL in the console will be remotely reset and it will not longer appear on the Studio speakers for as long as the Pin is powered.

12.3 BLOCK DIAGRAM

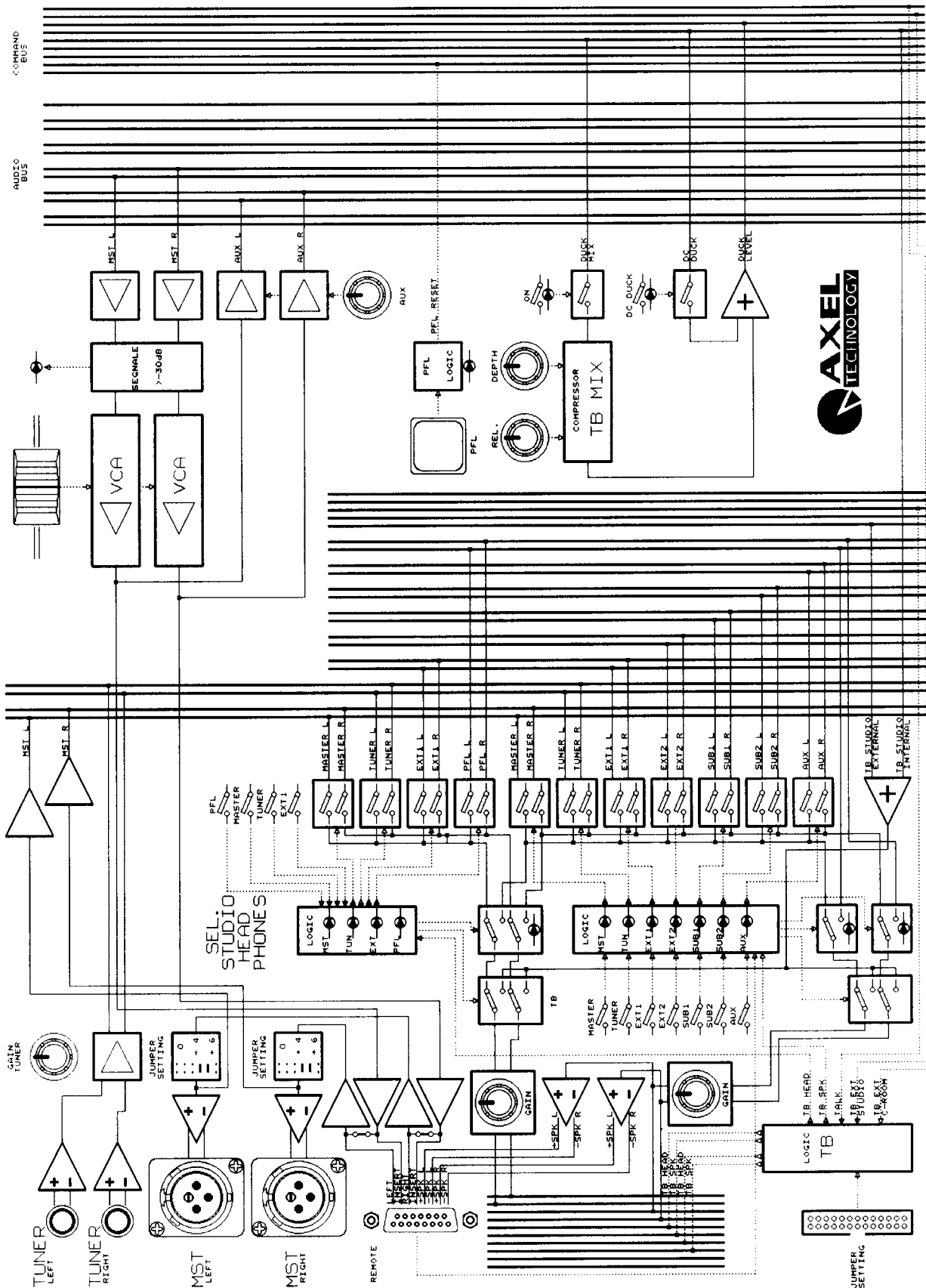

12.4 INTRODUCTION

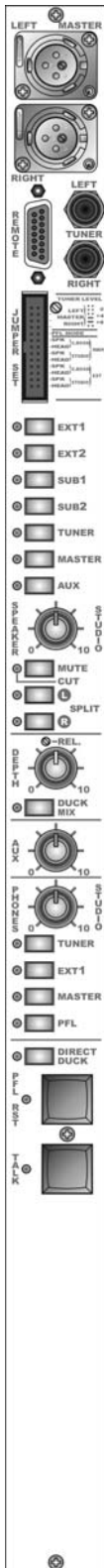

The Master module contains the **Master** main **outputs**.

It contains the monitoring controls for the Studio booth speaker and headphones.

The module includes a two-way Talkback System with routing provision also for external TalkBack signals. A Tuner input is also provided, which is intended to be connected to off-air, microwave, or satellite receivers

Master module contains also control section for manual and automatic duck circuitries.

A significant feature of the Oxygen 7 is that it features separate mono and stereo Master outputs. For example, mono main output (situated on the Monitor module) can fed AM transmitters, while stereo outputs may fed FM transmitters.

Master Outputs are electronically balanced, have a nominal level of 0 dBu, and are capable of driving balanced or unbalanced loads of 600 ohms or greater.

12.5 MASTER output

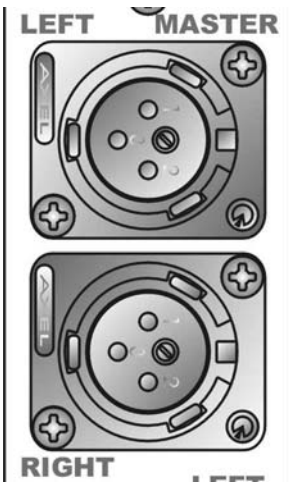

MASTER output is electronically balanced on XLR connectors and can drive balanced or unbalanced loads of 600 ohms or greater.

All the consoles are set for a 0 dBm Master output level at the time of factory test.

Master output is however compatible with nominal level of **+4 dBm** and **+6 dBm**.

Four jumpers, located on the front panel of the module, are used to set the output sensitivity. Refer to the *module jumper setting* 12.7 section of this guide for configuration details.

The Master outputs Left and Right have their own insertion points. These inserts are intended to accept external limiters, compressors, effect units, etc.. Refer to the *Remote Interface* section of this guide for configuration details. **As the Master signal for monitoring is taken across the XLR output connectors**, Insert Master circuitry allows You to easily listen to the final result of Master signal + external (inserted) effect.

12.6 TUNER input

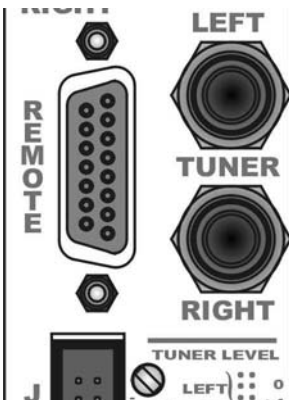

In addition to monitoring the Master and Sub audio buses, provision has been made for monitoring an external audio source. This stereo input (Tuner) is intended to be connected to microwave, FM or satellite receivers, etc. The Input is electronically balanced on 1/4" plugs.

A recessed **TUNER LEVEL trimmer** allows you to adjust the level of the Input signal to be monitored by the Studio/Control Room speakers and phones in a ± 6 dB range.

12.7 MODULE OPTIONS AND JUMPER SETTINGS

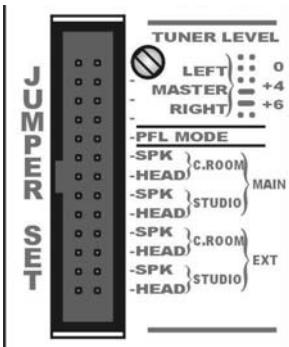

The first four jumpers select the **Master output level** (ref to Section 12.5). Close Jumpers accordingly to the configurations here below displayed

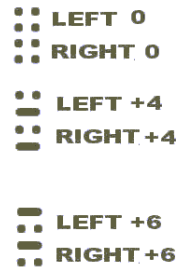

NOTE The Meter setting can also be altered, so that (Ref to Section 15.3):

- a +6dBu signal level, as measured across the XLR connectors, results in a reading of 0 VU on the meters
- a +4dBu signal level, as measured across the XLR connectors, results in a reading of 0 VU on the meters

The **PFL MODE** jumper allows two PFL operating modes.

- When the jumper is **opened**, pressing any input PFL automatically replace any other currently selected PFL, so that only one PFL is active at once.
- When the jumper is **closed**, any input PFL will be automatically summed to any other currently selected one. You can listen to one or more PFLs at the same time by pressing one or more PFL keys.
To deselect, press PFL button again or press 'PFL Reset' to deselect all active PFLs.

PFL RESET key will always disable all the active PFL keys, regardless of the PFL MODE jumper.

TALKBACK ROUTING jumpers

Talkback lets the operator talk to one or more console outputs, for example to communicate with announcer in the Studio booth through the Studio monitor speakers or the Studio headphones. This section houses all controls needed to communicate with every connected source to the Oxygen 7.

When closed, the SPeaker / CROOM / MAIN jumper routes the signal from the TalkBack to CRoom (**internal**) Bus to the Croom speakers (see MONITOR module).

When closed, the HEADphones / CROOM / MAIN jumper routes the signal from the TalkBack to CRoom (**internal**) Bus to the Croom headphones (see MONITOR module).

When closed, the SPeaKer / STUDIO / MAIN jumper routes the signal from the TalkBack to Studio (**internal**) Bus to the Studio speakers (see MASTER module – Section 12.1).

When closed, the SPeaKer / STUDIO / MAIN jumper routes the signal from the TalkBack to Studio (**internal**) Bus to the Studio Headphones (see MASTER module – Section 12.1).

When closed, the SPeaKer / CROOM / EXT jumper routes the TalkBack to CRoom signal coming from the **external** Bus (ref to Section – Sub Module Section 11.1.3) to the Croom speakers (see MONITOR module).

When closed, the HEADphones / CROOM / EXT jumper routes the TalkBack to CRoom signal coming from the **external** Bus (ref to Section – Sub Module Section 11.1.3) to the Croom headphones (see MONITOR module).

When closed, the SPeaKer / STUDIO / EXT jumper routes the TalkBack to Studio signal coming from the **external** Bus (ref to Section – Sub Module Section 11.1.3) to the Studio speakers (see MASTER module – Section 12.1).

When closed, the HEADphones / STUDIO / EXT jumper routes the TalkBack to Studio signal coming from the **external** Bus (ref to Section – Sub Module Section 11.1.3) to the Studio headphones (see MASTER module – Section 12.1).

12.8 STUDIO SPEAKER section

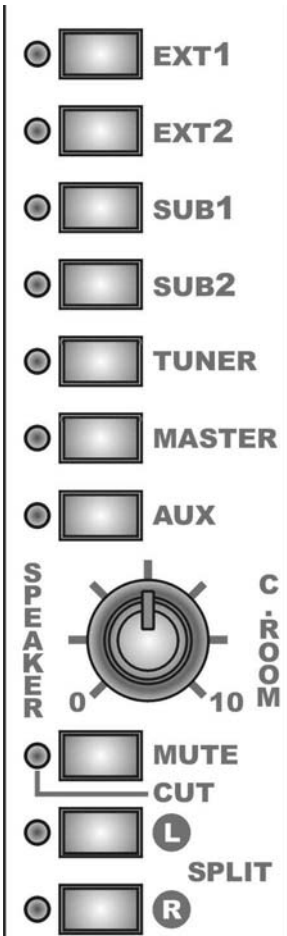

The core of the monitor section are the seven monitor source buttons. The buttons allow one or more of the audio sources (as well as PFL signal) to be selected for monitoring as the Studio speaker source.

Via proper contact closures, the source selection can be also remotely controlled (f.i. from the studio booth). Ref to Section 12.1.

The monitor source switches were chosen to allow more than one source to be selected at a time. This feature can prove useful in some specialized situations.

An example is where a mix-minus PFL (Cue) signal from a remotely located facility is being returned to the Oxygen 7 by means of External input 1. By selecting both EXT 1 and Master stereo, a composite signal is created for monitoring.

A smooth-feeling rotary control allows the control room level to be adjusted.

Studio Speaker Mute

The Mute function operates whenever an input channel is used which has been designated to mute the Studio monitors (*Studio Mute Jumpers*). This is to prevent acoustic feed-back (e.g. using a Studio microphone). CUT LED is fully lit whenever the mute function is active (regardless of Cut-off / Dim status – see hereunder).

Two ‘Mute’ operating mode (Cut / Dimmed) has been introduced in order to allow maximum operating flexibility.

CUT LED OFF	MUTE depressed	the ‘Mute’ command of any input module cuts the Studio speakers off
CUT LED HALF BRIGH.	MUTE pressed	the ‘Mute’ command of any input module dims the Studio speakers (L and R) by 20 dB
CUT LED ON		‘Mute’ command of any input module is active. The speakers are cut-off or dimmed <u>depending on the MUTE switch position</u>

For normal control room speaker operation the mute LED must not be lit.
NOTE: Mute function acts also on the SPLIT PFL circuit (see herebelow).

PFL Split L/R buttons

Two switchers (L and R) in addition to the Mute button set the PFL operating mode. Mute’ command of any input module is active. The speakers are cut or dimmed depending on the MUTE switch position

SPLIT L pressed	MUTE depressed	STUDIO speakers - Left channel will reproduce the PFL signal summed with the normal audio dimmed by 20 dB. Right channel is unaltered. 'Mute' command of any input module dims both the STUDIO speakers by 20 dB
SPLIT R pressed	MUTE depressed	STUDIO speakers - Right channel will reproduce the PFL signal summed with the normal audio dimmed by 20 dB. Left channel is unaltered. 'Mute' command of any input module dims both the STUDIO speakers by 20 dB
SPLIT L pressed	MUTE pressed	STUDIO speakers - Left channel will reproduce the PFL signal only (i.e PFL automatically overrides any currently selected output AFL or monitor source). Right channel is unaltered. 'Mute' command of any input module cuts both the STUDIO speakers off. This logic is ideal for quickly checking channel signals while monitoring a selected mix.
SPLIT R pressed	MUTE pressed	STUDIO speakers - Right channel will reproduce the PFL signal only (i.e PFL automatically overrides any currently selected output AFL or monitor source). Left channel is unaltered. 'Mute' command of any input module cuts both the STUDIO speakers off. This logic is ideal for quickly checking channel signals while monitoring a selected mix.
L & R SPLIT pressed		CRoom speakers will reproduce PFL signal summed with the normal audio dimmed by 20 dB. Both the speakers will be cut-off or dimmed depending on the MUTE switch position.

The SPLIT LEDs will illuminate at half brightness if PFL SPLIT buttons are pressed but no channels are set to PFL.

You may regard this as the PFL circuit being armed but not active.

To make it active the PFL status must be engaged in one or more channels. The LED will illuminate at full brightness to indicate that the PFL circuit is now active.

SPLIT switchers do not affect headphone monitoring section.

12.9 DUCK MIX section



As anticipated at the Chapter 6, Oxygen 7 incorporates **automatic ducking capabilities**. It means that the ducking circuitry allows any combination of MONO and TELCO inputs to duck (attenuate) one or more of the remaining modules (Stereo, Mono, Telco or Sub).

Auto ducking is triggered by signal present at the selected input Modules (see DUCK MIX selection on MONO and TELCO modules).

Duck Mix section comprises:

- REL(ease) control: it adjust the Release time for the duck circuit
- DEPTH level: it is the the amount of ducking that will occur . The attenuation will be always proportional to the driving source (i.e. Mono or Telco modules with DUCK MIX jumper closed).

To **allow automatic duck control**, follow these steps:

- 1) enable DUCK MIX option on the MONO and TELCO Modules that will drive the Duck circuitry (see **Duck Mix Jumper** in the Jumper setting section)
- 2) press DUCK MIX switch on the MASTER Module. Adjust the Release time for the duck circuit and the 'Duck ratio' . A duck LED will indicate that ducking is occurring and will indicate the 'ducking' level
- 3) press DUCK switch on the modules to be 'ducked'

12.10 AUX control



This control sends the stereo Master signal to the Auxiliary bus (range $-\infty$ to 0 dB max).

12.11 Control Room HEADPH. section

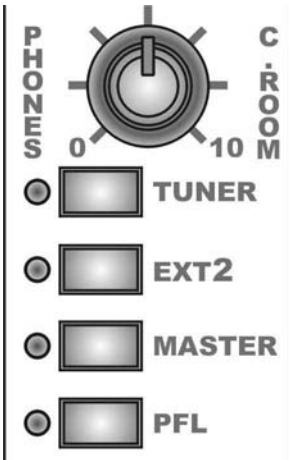

The STUDIO PHONES section will affect the output to any headphones connected to the 1/4" jack Studio phones socket. The phones level can be adjusted by use of the level knob which alters the output between cutoff, when set to 0, and maximum level, at 10.

The "pot" sets the output level for the three headphone output jacks (bottom and top).

Signals to be monitored by the Studio headphones are selected by using the buttons below the Studio phones volume control.

They can be used to monitor any combination (also mixed) of the Master output, the External 2 Input (i.e. external signal connected to Sub 2 module – Ref to Section 11.1.1) or the Tuner Input. When a red LED is illuminated, it indicates that the signal is routed to the phones.

External and Tuner Inputs are normally used for monitoring the off-air signal or another studio.

With the PFL button pressed, any channels set to PFL are automatically routed to the Studio headphones, independently of the Studio Speaker monitors.

The PFL LED will illuminate at half brightness if the PFL Switch is pressed but no channels are set to PFL.

You may regard this as the PFL circuit being armed but not active.

To make it active the PFL status must be engaged in one or more channels. The LED will illuminate at full brightness to indicate that the PFL circuit is now active.

LED OFF switch depressed / the PFL status of any module doesn't affect HeadPhones monitor circuit

LED ON switch pressed / PFL monitoring is active (i.e. PFL signal appears on the Headphones) as one or more modules are set to PFL

LED HALF BRIGH. switch pressed / PFL circuit is active but no channels are set to PFL

This three mode operating has been introduced in order to prevent buss from additional noise when routing switchers are pressed and modules are not set to PFL.

NOTE: if no source is selected in the Studio Headphone section, phones automatically will follow the Studio Speaker selection.

This allows the user to monitor to some extra-source (as the Sub outputs) not available in the HP section.

SPLIT switchers do not affect headphone monitoring section.

12.12 DIRECT DUCK



The Direct Duck switch allows an **external master fader** (e.g. the DJ Console) controlling the whole mix of the channels where 'duck' control is activated.

To activate the external master control:

- 1) connect the 'Duck Master' potentiometer (e.g. the Axel Technology's DJ Console) to one of the 'Mono Module Remote Interface'.
- 2) press DIRECT DUCK switch on the MASTER Module
- 3) press DUCK switch on the modules to be 'ducked'

12.13 PFL RESET button

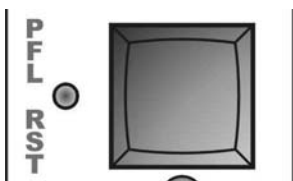

Depressing this large button resets all activated PFLs in all input channels and Sub modules.

See also Section 12.7 – PFL MODE Jumper

12.14 TALK BACK button

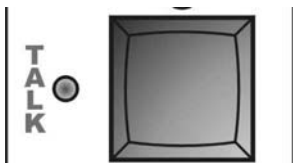

The TALK button allows people in the Control Room to transmit talkback to the Studio Speakers and Studio headphones when the button is pressed and viceversa (i.e. from TB button allows communications from Studio to Control Room Headphones and/or Speakers).

A) SPEAKERS: Talkback source will replace or dim their existing sources depending on the MUTE button (MUTE pressed: existing sources are cut off; MUTE depressed: existing sources are dimmed).

B) HEADPHONES Talkback source will always replace their existing sources.
(Croom/Studio speakers & headphones outputs are driven pre- their volume controls, so communication is possible only with volume raised..)

When pressing Talk button:

- talkback signal toward CRoom speakers / headphones comes from all the MONO and TELCO modules with 'TB to Croom' option enabled
- talkback signal toward Studio speakers / headphones comes from all the MONO and TELCO modules with 'TB to Studio' option enabled.

Please remind that TB signal to Studio/Croom appears on

Studio/Croom Speakers/Headphones ONLY with TB Routing jumpers closed accordingly (ref to Section 12.7).

The Talk button does not affect External TB signal enabling/routing (ref to Section 11.1 – Sub Module) .

EXAMPLES

Example 1

Communication from the audio engineer to the announcer's headphones (situated in the Studio booth) will be enabled in the following way:

- 1) Close the Jumper 'TB to Studio' on the MONO module connected to a Croom's microphone
- 2) Close the jumper Main / Studio / Headphones on the MASTER module (ref to to Section 12.7)
- 3) Press and hold the Talk button: it will connect the Engineer's voice audio source to the Studio headphone output. The voice audio signal will replace whatever signals are also present on the HP output.

Example 2

Communication from the announcer (situated in the Studio booth) and the audio engineer (via C Room speakers) will be enabled in the following way:

- 1) Close the Jumper 'TB to Croom' on the MONO module connected to the Studio announcer's microphone
- 2) Close the jumper Main / CRoom / Speakers on the MASTER module (ref to to Section 12.7)
- 3) Remote enable the TB via the Mono Module Remote Interface. Press and hold the remote Talk button: it will connect the announcer's voice source to the CROOM Speaker output. Monitor speakers are automatically muted (or dimmed, depending on MUTE button) whenever talk back function is active.

13 MONITOR MODULE

13.1 MONITOR MODULE - REMOTE CONNECTOR

The 15 pin D-Type plug remote connector provides the inputs and outputs for the following functions :

- Stereo line-level (max + 10 dB) output for connection to a power amplifier associated with a pair of **control room** monitor loudspeakers. The output is electronically balanced, and can drive balanced or unbalanced loads of 600 ohms or greater. To connect to an unbalanced load tie the Cold pole to GND.
- Stereo AUX bus output (line level). The output is electronically balanced, and can drive balanced or unbalanced loads of 600 ohms or greater.

A 6 Vdc \pm 50 mV current-limited output is also provided.

13.2 INTERFACE PIN-OUT

SUB D 15P FEMALE

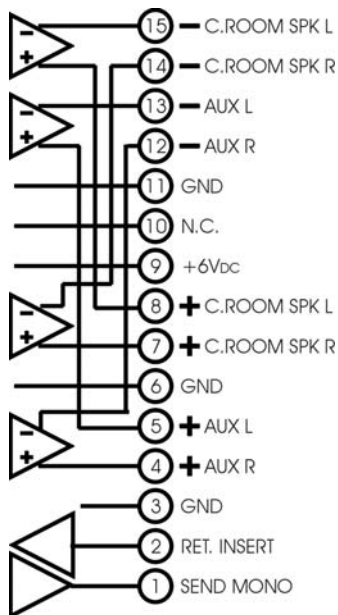

PIN	DESCRIPTION	DIRECTION
15	Ctrl Room speaker output Cold (Out-of-Phase) Left channel	OUT
14	Ctrl Room speaker output Cold (Out-of-Phase) Right channel	OUT
13	AUX Output / Cold (Out-of-Phase) Left channel	OUT
12	AUX Output / Cold (Out-of-Phase) Right channel	OUT
11	Ground GND	/
10	Not Connected	/
9	+ 6 V DC	OUT
8	Ctrl Room speaker output Hot (in-Phase) Left channel	OUT
7	Ctrl Room speaker output Hot (in-Phase) Right channel	OUT
6	Ground GND	/
5	AUX Output / Hot (in-Phase) Left channel	OUT
4	AUX Output / Hot (in-Phase) Right channel	OUT
3	Ground GND	/
2	Not Connected	IN
1	Not Connected.	OUT

13.3 BLOCK DIAGRAM

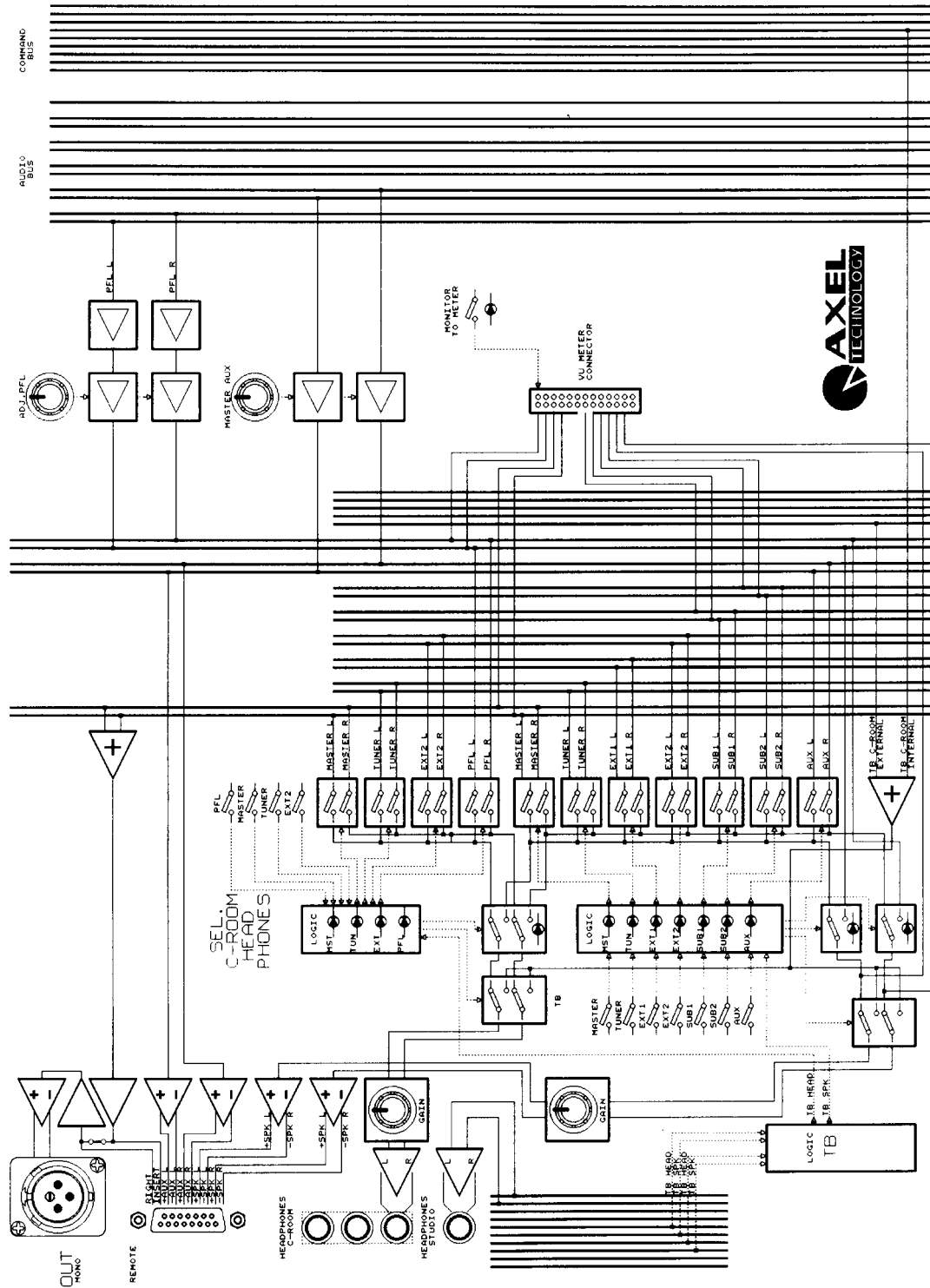

13.4 INTRODUCTION

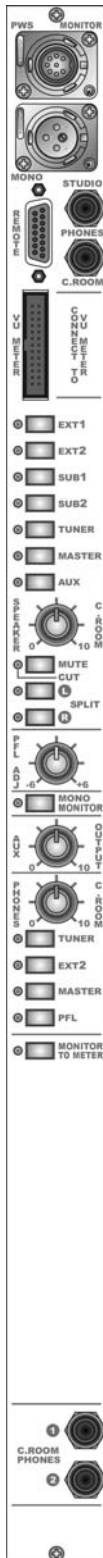

Oxygen 7's Monitor module gives the operator an extensive set of resources. The monitor module assists the operator in obtaining the best performance from the Oxygen 7. It controls the signals that are presented to the VU meters, Control Room speaker output and headphone output. It allows also aural monitoring of a variety of signals without interfering with normal operation of the main audio bus.

Separate stereo outputs and level controls are provided for connection to **Control Room** monitor amplifier and headphones.

In addition to monitoring the Master, Sub1 and Sub 2 audio buses, provision has been made for monitoring three external audio sources (Ext 1, Ext 2 and Tuner) plus the AUX bus.

Volume controls for Croom sources, Aux and PFL are included. The module includes a Monophonic Master Output, the AUX bus output and a jack 1/4" socket for Studio Headphones.

13.5 PWS input

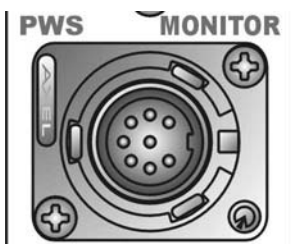

The 8-way locking PWS (POWER SUPPLY) connector is the power input for the mixing console. The Oxygen 7 requires +17V, -17V, +6V, -6V and +48V.

13.6 MONO output



The Mono output connector provides a monaural version of Master signal. The mono function sums (adds) the left and right Master channels, drops the level 6 dB, and sends the resulting signal to the Mono output. The level is factory preset at 0 dB and can not be adjusted.

13.7 STUDIO – C.ROOM Headph sockets

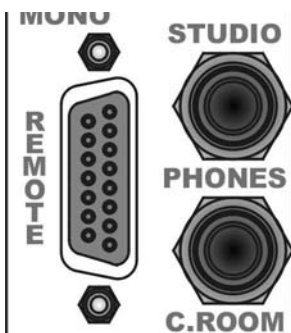

The Monitor module contains two separate stereo headphone power sections (2 x 14 W on 8 Ω loads) that are capable of driving multiple pairs of headphones each one without need of external additional amplifiers.

For flexibility, CRoom headphone output jacks are provided on both the top (1) and bottom (2) of the module and are internally parallel connected. Studio headphone output is located only at the top of the Monitor module.

13.8 VU METER connection

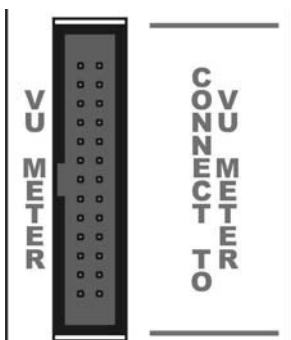

This is male multi-pin socket which connects the Oxygen 7 mixer to the Meterbridge. Ref also to Chapter 15.

13.9 Control Room SPEAKER section

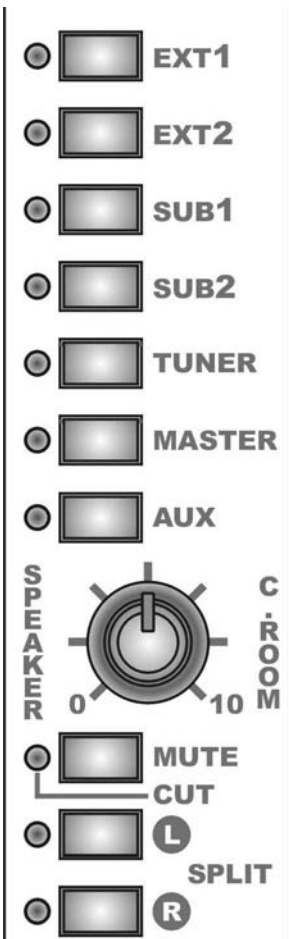

The core of the monitor section are the seven monitor source buttons. The buttons allow one or more of the audio sources (as well as PFL signal) to be selected for monitoring as the Control Room speaker source. Remote selection control is not provided.

The monitor source switches were chosen to allow more than one source to be selected at a time. This feature can prove useful in some specialized situations.

An example is where a mix-minus PFL (Cue) signal from a remotely located facility is being returned to the Oxygen 7 by means of External input 1. By selecting both EXT 1 and Master stereo, a composite signal is created for monitoring.

A smooth-feeling rotary control allows the control room level to be adjusted.

Control Room Speaker Mute

The Mute function operates whenever an input channel is used which has been designated to mute the Croom monitors (*Control Room Mute Jumpers*). This is to prevent acoustic feed-back (e.g. using a Control Room microphone). CUT LED is fully lit whenever the mute function is active (regardless of Cut-off / Dim status – see hereunder).

Two 'Mute' operating mode (Cut / Dimmed) has been introduced in order to allow maximum operating flexibility.

CUT LED OFF	MUTE depressed	the 'Mute' command of any input module cuts the Croom speakers off
CUT LED HALF BRIGH.	MUTE pressed	the 'Mute' command of any input module dims the Croom speakers (L and R) by 20 dB
CUT LED ON		'Mute' command of any input module is active. The speakers are cut-off or dimmed <u>depending on the MUTE switch position</u>

For normal control room speaker operation the mute LED must not be lit.
NOTE: Mute function acts also on the SPLIT PFL circuit (see herebelow).

PFL Split L/R buttons

Two switchers (L and R) in addition to the Mute button set the PFL operating mode. Mute' command of any input module is active. The speakers are cut or dimmed depending on the MUTE switch position

<p>SPLIT L pressed</p>	<p>MUTE depressed</p>	<p>CR speakers - Left channel will reproduce the PFL signal summed with the normal audio dimmed by 20 dB. Right channel is unaltered. 'Mute' command of any input module dims both the CR speakers by 20 dB</p>
<p>SPLIT R pressed</p>	<p>MUTE depressed</p>	<p>CR speakers - Right channel will reproduce the PFL signal summed with the normal audio dimmed by 20 dB. Left channel is unaltered. 'Mute' command of any input module dims both the CR speakers by 20 dB</p>
<p>SPLIT L pressed</p>	<p>MUTE pressed</p>	<p>CR speakers - Left channel will reproduce the PFL signal only (i.e PFL automatically overrides any currently selected output AFL or monitor source). Right channel is unaltered. 'Mute' command of any input module cuts both the CR speakers off. This logic is ideal for quickly checking channel signals while monitoring a selected mix.</p>
<p>SPLIT R pressed</p>	<p>MUTE pressed</p>	<p>Croom speakers - Right channel will reproduce the PFL signal only (i.e PFL automatically overrides any currently selected output AFL or monitor source). Left channel is unaltered. 'Mute' command of any input module cuts both the CR speakers off. This logic is ideal for quickly checking channel signals while monitoring a selected mix.</p>
<p>L & R SPLIT pressed</p>		<p>CRoom speakers will reproduce PFL signal summed with the normal audio dimmed by 20 dB. Both the speakers will be cut-off or dimmed depending on the MUTE switch position.</p>

The SPLIT LEDs will illuminate at half brightness if PFL SPLIT buttons are pressed but no channels are set to PFL. You may regard this as the PFL circuit being armed but not active. To make it active the PFL status must be engaged in one or more channels. The LED will illuminate at full brightness to indicate that the PFL circuit is now active.

SPLIT switchers do not affect headphone monitoring section.

13.10 PFL ADJ potentiometer



The PFL ADJ rotary level control is used to set the overall PFL level relative to the normal audio level within a ± 6 dB range. Set the trim pot so as to give a comfortable level of 'PFL' signal to the headphone and speaker outputs.

13.11 MONO MONITOR switch



The MonoMonitor push-button switch allows to activate the monaural function on Control Room speakers. The switch is electrically set for latching operation; press once to active mono, press again to go back to stereo.

An LED displays mono status.

The mono function sums (adds) the left and right source(s), drops the level 6 dB, and sends the resulting signal to both the left and right control room outputs.

13.12 AUX Output control



The AUX OUTPUT rotary level control is used to set the overall AUX level. Access to the AUX bus is provided by means of an electronically balanced, line level output on the Remote Interface (ref to § 13.1).

13.13 Control Room HEADPH. section

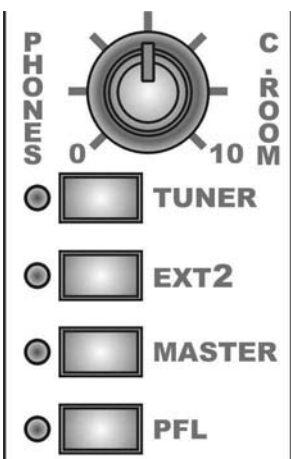

The CONTROL ROOM PHONES section will affect the output to any headphones connected to the 1/4" jack CRoom phones socket. The phones level can be adjusted by use of the level knob which alters the output between cutoff, when set to 0, and maximum level, at 10.

The "pot" sets the output level for the three headphone output jacks (bottom and top).

Signals to be monitored by the Control Room headphones are selected by using the buttons below the C.Room phones volume control.

They can be used to monitor any combination (also mixed) of the Master output, the External 1 Input (i.e. external signal connected to Sub 1 module – Ref to Section 11.1.1) or the Tuner Input. When a red LED is illuminated, it indicates that the signal is routed to the phones.

External and Tuner Inputs are normally used for monitoring the off-air signal or another studio.

With the PFL button pressed, any channels set to PFL are automatically routed to the CRoom headphones, independently of any setting operated

in the CRoom Speaker monitor section.

The PFL LED will illuminate at half brightness if the PFL Switch is pressed but no channels are set to PFL.

You may regard this as the PFL circuit being armed but not active.

To make it active the PFL status must be engaged in one or more channels. The LED will illuminate at full brightness to indicate that the PFL circuit is now active.

LED OFF switch depressed / the PFL status of any module doesn't affect HeadPhones monitor circuit

LED ON switch pressed / PFL monitoring is active (i.e. PFL signal appears on the Headphones) as one or more modules are set to PFL

LED HALF BRIGH. switch pressed / PFL circuit is active but no channels are set to PFL

This three mode operating has been introduced in order to prevent buss from additional noise when routing switchers are pressed and modules are not set to PFL.

NOTE: if no source is selected in the CRoom Headphone section, phones automatically will follow the CRoom Speaker selection.

This allows the user to monitor to some extra-source (as the Sub outputs) not available in the HP section.

SPLIT switchers do not affect headphone monitoring section.

13.14 MONITOR TO METER switch



The **Monitor To Meter** button determines what is shown on the *main* Vu meters. When the button is in the up position, the Master signal only is shown at the meters.

With the button depressed and the LED illuminated, the levels of Ext1, Ext2, Sub1, Sub2, Tuner, Master or Aux signals can be displayed, depending on the selected source in the Control Room Speaker section.

For example, if *Monitor To Meter* is selected for the meters, and the Control Room Speaker section has *Tuner* selected, then the meters will display the *Tuner* signal.

13.15 C.ROOM headphone sockets

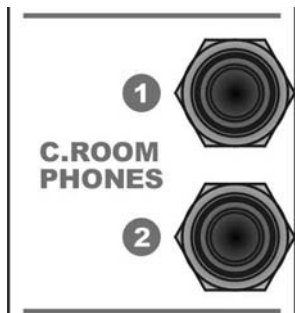

Two 1/4" stereo jack sockets provide outputs for a pair of Control Room phones. Control Room headphones can be plugged also on the top of this module.

The simplest way of using the headphone output is simply to plug a pair of headphones into the bottom panel jack. In other applications it may be convenient to wire connector panels located in a control room, studio, or voiceover booth to the top-panel headphone output.

14 POWER SUPPLY

FRONT VIEW

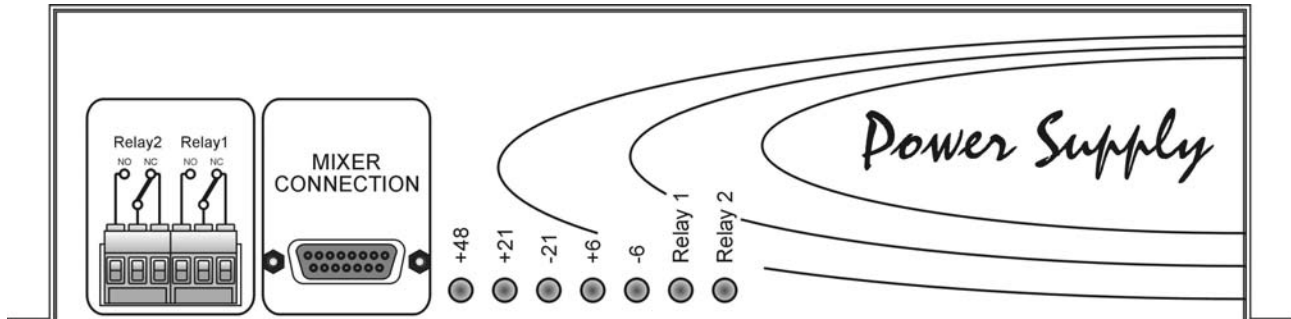

REAR VIEW

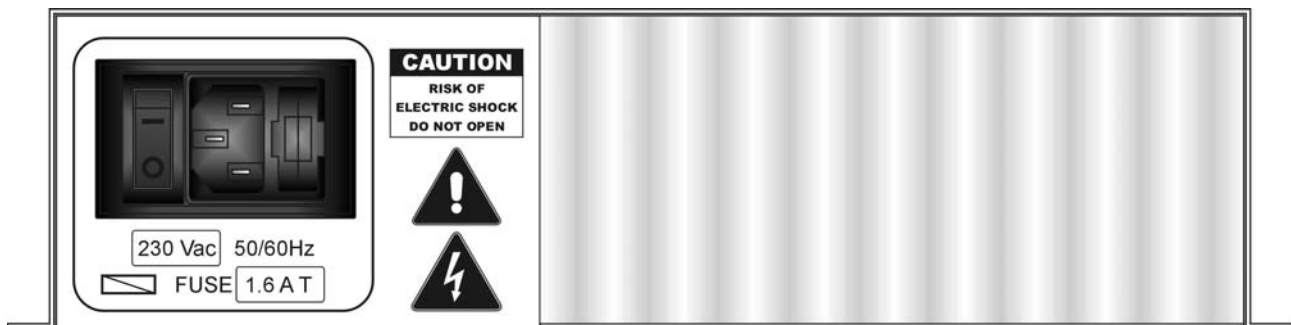

14.1 Description

The Oxygen 7 Power Supply (PWS) consists of a power transformer, selectable for 115 VAC or 230 VAC operation, rectifiers, filter capacitors and voltage regulators on a circuit board.

The power supply is protected by a replaceable AC mains fuse located in the power entry socket plus internal fuses on the transformer's secondary outputs and selfprotected current-limiting regulators.

The power supply has five output voltages:

- ± 21 volts for the audio circuitry
- ± 6 volts for the logic circuitry
- +48 volts phantom for condenser microphones.

Five LEDs on the front of the unit indicate whether the power to the five voltage rails is being supplied correctly. if one of the led's fails, then there is a problem with the PWS unit or the console. Ref to § 14.5.

The power supply should be installed where there is adequate ventilation for heat to circulate from the rear and the side of the unit.

14.2 PWS RELAYS

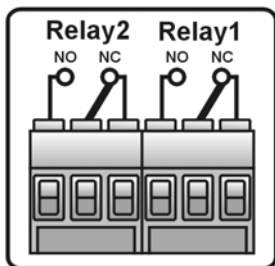

The power supply features two built-in relays separately controlled by some modules.

They are mainly designed to illuminate external Studio and/or Control Room Warning/On Air lights (such as Mr Light by Axel Technology) showing that one or more microphones are 'on air'.

Relays are intended for **low voltage** electric loads (e.g. 24 V), **up to 10 A**.

FOR SAFETY AND TO PROTECT THE OPERATOR FROM HIGH VOLTAGE SHOCK, NEVER CONNECT AC MAINS TO PWS RELAYS.

Use relays to directly control low-voltage lamps or to drive 220 / 115 Vac Lamps via external relays or optocouplers.

The Oxygen 7's PWS relays feature either Normally Open or Normally Closed contacts. Two LEDs on the front of the unit indicate whether the relays are closed.

14.3 MIXER CONNECTIONS



A cable with a 15 pole plug on each end comes with the console. It is used to connect the power supply to the mixer.

Plug the cable into the power supply MIXER CONNECTION socket. Press the plug into the socket, and screw on the locking ring to hold it firmly in place. Plug and secure the other end into the console PWS socket on *Monitor* module.

Turning the Console On or Off: First check that the mains and DC leads are correctly plugged in and secured. Turn on the power supply using its rear panel mains switch. The console must be connected to the power supply before turning it on. To avoid loud pops in the speakers make sure that the connected power amplifiers are turned off before switching the console on or off.

14.4 MAIN AC VOLTAGE Settings

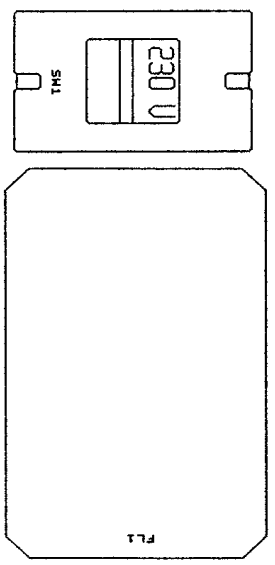

Before connecting the Oxygen 7 to mains power, determine the actual mains voltage and confirm that the Oxygen 7 PWS has been configured correctly. As could be expected, an incorrect mains configuration could seriously damage the unit.

If the unit is to be used with a mains voltage different to that for which the unit is supplied, set the **voltage change-over switch**, which is placed inside the box, closed to the AC socket and the AC filter.

The power supply socket has an integral **fuse drawer** containing the AC power fuse and a spare, both of the same value, rated at 1600 mA T for 220/230 V AC and at 2500 mA for 110/115 V AC tensions.

Make sure that the IEC mains plug is pressed fully into the MAINS INPUT socket.

WARNING: The power must be switched off at the supply or the power lead must be disconnected before attempting to remove the panels or cover. Removal of the panels and cover can expose dangerous voltages.

14.5 PWS TROUBLESHOOTING

- +48
- +21
- -21
- +6
- -6

The correct operation of power supply is showed by the 5 LEDs glowing on the front panel. If the console doesn't work properly, please check the power connection cable.

If the neon lamp inside the **Main switch is off** (and therefore all LED on the power supply front panel are off), please check the Main Fuse next to the line cord socket (1600 mA T at 220 V or 2500 mA T at 115 V).

If one or more LED on the panel of power supply are switched off (and therefore console doesn't work properly) please execute the following steps:

- disconnect the console from the PWS
- switch the PWS on
- verify that every LED on the front panel glow (except Relay 1 and 2)

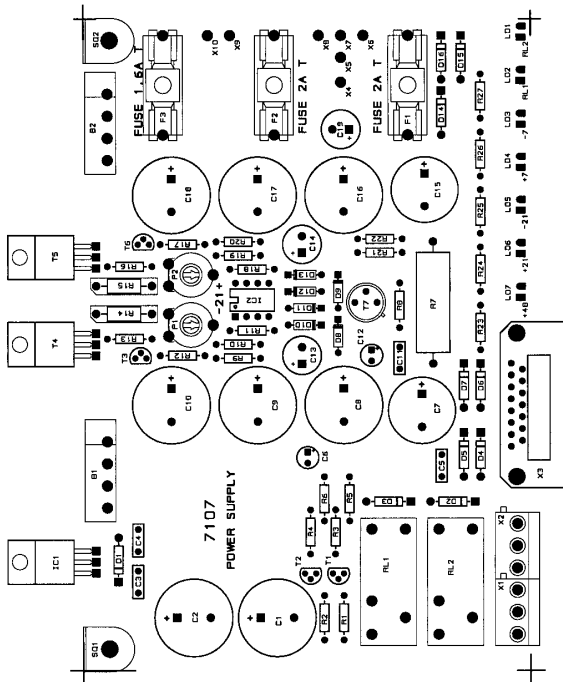

If one or more LEDs are still switched off:

- open the PWS cover
- verify the **integrity of the 2 fuses on the PCB** and replace the burned ones (2 fuses are rated to 2 A T and one to 1.6 A T)
- close up the cover
- connect the line cord only
- switch on the power supply again and check if LEDs are on Note: if the problem still persists, please contact Axel Technology technical department
- switch the power supply off
- connect the mixing console to the PWS
- switch the PWS on
- Verify the correct mixing console operation

15 METERBRIDGE



15.1 INTRODUCTION

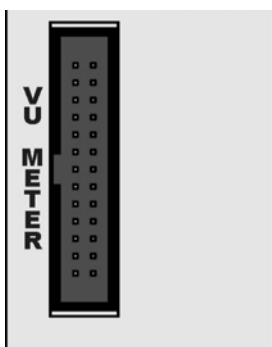

The Oxygen 7 mixer is fitted with as standard 3 mechanical VU-type meters, providing an userfriendly indication of audio-signal levels. They have reasonably slow dynamics (attack and release) and they are therefore good at displaying the average music programme. The scale is restricted between -20 and +5 VU to provide good resolution around average reading.

'Master' VU Meters are parallel connected to the output Master connectors (i.e. they are connected across the output XLRs).

Allowing the meters to directly monitor the XLR outputs is provided for operator peace-of-mind. It allows a continuous display of what is going on air, no matter what is happening in the monitor section.

Note: when the *Monitor to Meter* button is set to its released position, use of the Speaker Selection buttons will have no impact on the meters.

VU Meters are factory-calibrated to indicate 0 VU with 0 dBm output on the balanced XLR connectors *. This serves as a visual alarm if the output is short-circuited or improperly wired. Further user settings are allowed – Ref to Section 15.3.

A 26 pole flat cable connects the meterbridge to the mixer.

The VU meters are illuminated by single cartridge-type, 12V, 1.2 Watt incandescent lamps, operating well under its normal rating for a life expectancy of greater than 10,000 hours.

The VU meter lamps are connected on the 12 V rail (+/- 6V) of the PWS and make the meters easy to read under all lighting conditions.

** If a 1kHz sinusoidal signal is input to the mixer and the amplitude adjusted such that the level at the master output is 0 dBm, the meters will read 0 VU*

15.2 VU METER ASSIGNMENTS

The RIGHT pair of meters display as default Master bus stereo output.

They can also be altered to show any combination of the Master output, the Sub output, Tuner input, EXT inputs or whatever is selected on the **Control Room** /Speaker section of **Monitor** module (Split mode included) when the "MONITOR TO METER" button is pressed (see § 13.14).

For example, if SELECTION TO METER button is pressed and the CONTROL ROOM has SUB 1 selected, then the meters will display the SUB 1 signal.

The LEFT VuMeter displays as default the PFL (CUE) signal (MONO). Whenever the PFL RESET condition is entered (PFL RESET LED glows), the VuMeter displays the MONO Master Output.

15.3 VU METER SETTING

From the factory the VU meters are calibrated so that a +0dBu signal level, as measured across the XLR connectors, results in a reading of 0 VU on the meters.

The Meter setting can be altered, so that :

- a +6dBu signal level, as measured across the Master (L&R) XLR connectors, results in a reading of 0 VU on the meters
- a +4dBu signal level, as measured across the Master (L&R) XLR connectors, results in a reading of 0 VU on the meters

Jumper setting is shown at the next page

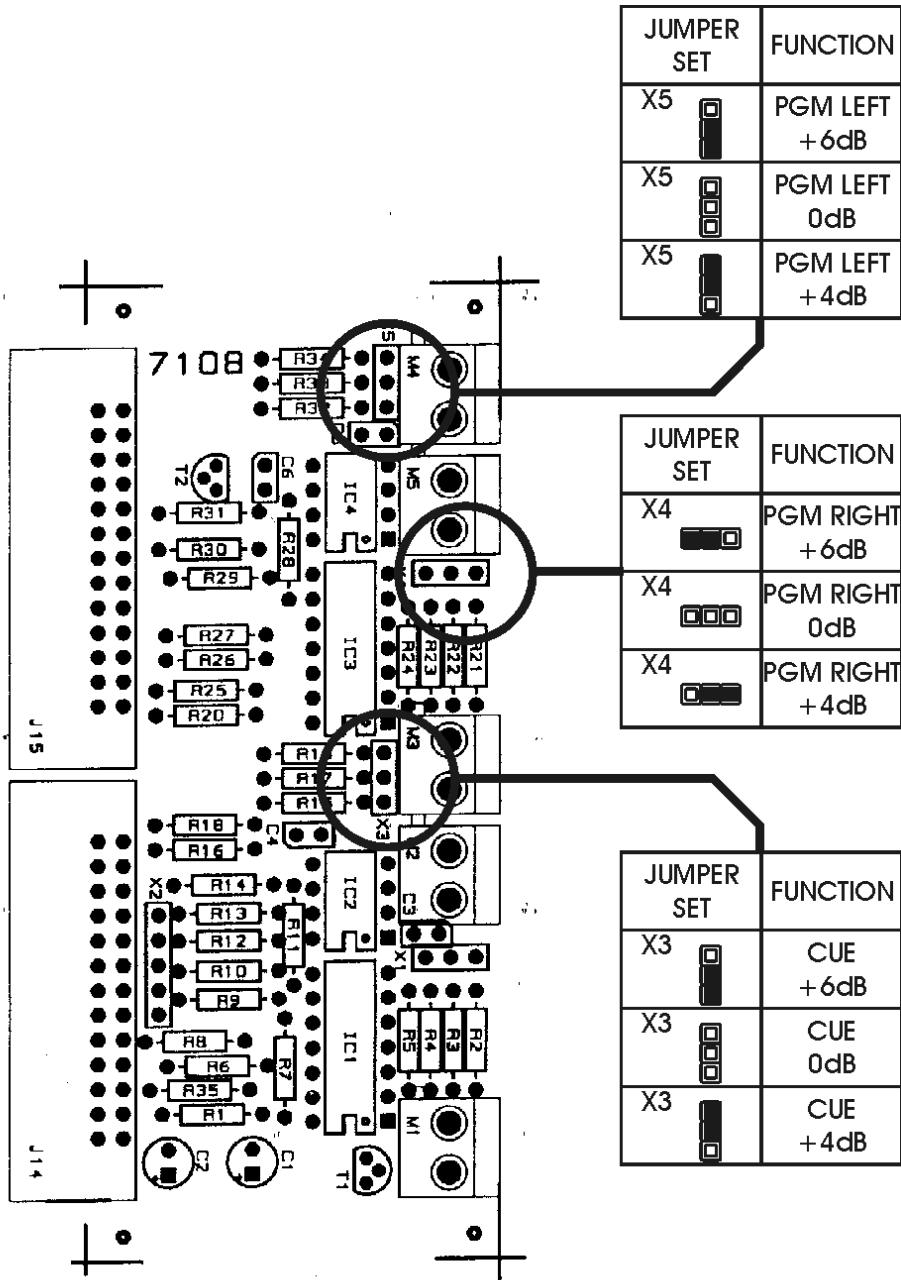

16 WARRANTY

The manufacturer offers a 1-year ex works warranty.
Do not open the equipment. The warranty shall be voided if any of the warranty seals are broken.
The manufacturer shall not be liable for damage of any kind deriving from or in relation to incorrect use of the product.

17 DIMENSIONS

